

**FINAL REPORT**

**COMMERCIAL MOTOR VEHICLE PARKING TRENDS AT  
REST AREAS AND WEIGH STATIONS**

**FDOT Contract No.: BDK80 977-14**

**Mehmet Emre Bayraktar, Ph.D., Associate Professor**

**Yimin Zhu, Ph.D., Associate Professor**

**Farrukh Arif, Graduate Research Assistant**

OHL School of Construction  
College of Engineering and Computing  
Florida International University  
10555 West Flagler St.  
Miami, FL 33174

Submitted to:

**Florida Department of Transportation**  
Research Center  
605 Suwannee Street, MS30  
Tallahassee, FL 32399

**December 2012**

## **DISCLAIMER**

The opinions, findings, and conclusions expressed in this publication are those of the authors and not necessarily those of the State of Florida Department of Transportation.

## APPROXIMATE CONVERSIONS TO SI UNITS

SYMBOL	WHEN YOU KNOW	MULTIPLY BY	TO FIND	SYMBOL
<b>LENGTH</b>				
<b>in</b>	inches	25.4	millimeters	mm
<b>ft</b>	feet	0.305	meters	m
<b>yd</b>	yards	0.914	meters	m
<b>mi</b>	miles	1.61	kilometers	km

SYMBOL	WHEN YOU KNOW	MULTIPLY BY	TO FIND	SYMBOL
<b>MASS</b>				
<b>oz</b>	ounces	28.35	grams	g
<b>lb</b>	pounds	0.454	kilograms	kg
<b>T</b>	short tons (2000 lb)	0.907	megagrams (or "metric ton")	Mg (or "t")

SYMBOL	WHEN YOU KNOW	MULTIPLY BY	TO FIND	SYMBOL
<b>TEMPERATURE (exact degrees)</b>				
<b>°F</b>	Fahrenheit	$5 (F-32)/9$ or $(F-32)/1.8$	Celsius	<b>°C</b>

## TECHNICAL REPORT DOCUMENTATION PAGE

1. Report No.	2. Government Accession No.	3. Recipient's Catalog No.	
4. Title and Subtitle  Commercial Motor Vehicle Parking Trends At Rest Areas And Weigh Stations		5. Report Date December 26, 2012	
		6. Performing Organization Code	
7. Author(s) Mehmet Emre Bayraktar, Yimin Zhu and Farrukh Arif		8. Performing Organization Report No.	
9. Performing Organization Name and Address  OHL School of Construction Florida International University 10555 West Flagler Street, EC 2900 Miami, FL 33174		10. Work Unit No. (TRAIS)	
		11. Contract or Grant No. BDK80 977-14	
12. Sponsoring Agency Name and Address  Florida Department of Transportation 605 Suwannee Street Tallahassee, FL 32399		13. Type of Report and Period Covered Final Report March 2011 – January 2013	
		14. Sponsoring Agency Code	
15. Supplementary Notes			
16. Abstract  The major objectives of this research included: i) to determine trends for truck parking at public rest areas throughout Florida and ii) to develop a suitable smart parking management system for commercial motor vehicles and conduct a pilot project. The data collection efforts over the course of this research enabled the research team to determine the level of truck parking capacity problem experienced at each rest area in Florida. This information was used to divide the rest areas into three categories, low, medium, and high, based on the "level of truck parking capacity problem," and depicted the rest areas on a color-coded map for I-10, I-75, and I-95; green was used for a low parking capacity problem, yellow for a medium parking capacity problem, and red for a high parking capacity problem. This research also included an assessment of technology that can be used to improve truck parking management at rest areas in Florida and deployment of a pilot project to test implementation. The vehicle detection technology chosen for the pilot project at the Leon County rest areas (eastbound and westbound) on I-10 features wireless ground sensors, which detect the presence of a vehicle as it comes to a stop above it. Over the course of this research, various software tools were developed to complement the wireless vehicle detection system described above, including a GIS mapping application, a report generation module, and an occupancy prediction model.			
17. Key Word commercial vehicles, rest areas, ITS, sensors, Kalman filter, parking management		18. Distribution Statement No restriction.	
19. Security Classif. (of this report) Unclassified	20. Security Classif. (of this page) Unclassified	21. No. of Pages 140	22. Price

## **EXECUTIVE SUMMARY**

The steady growth of commercial truck travel has led to an increasing demand for truck parking spaces at public rest areas on interstate highways in Florida. This research sought to understand the truck parking problem in Florida, determine the supply and demand characteristics for commercial truck parking, assess technology that can be used to improve parking management, and conduct a pilot project to test a smart truck parking management technology to increase operational efficiency of commercial drivers and reduce truck parking on shoulders, crashes due to driver fatigue, and unnecessary diesel emissions. The major objectives of this research included: i) Phase-1: to determine trends for truck parking at public rest areas throughout Florida and ii) Phase-2: to develop a suitable smart parking management system for commercial motor vehicles and conduct a pilot project.

Phase-1 involved collection of field observation data by the research team at all of the public rest areas along the I-10, I-75, and I-95 corridors. In order to manage the data collection process effectively, the research team defined seven (7) segments on the Interstate System, which would typically include three to five consecutive public rest areas. The research team drove along these segments during nighttime over a two-to-three-day period per segment, and visited each facility in the segment at least once per night to collect data regarding its supply and demand characteristics. The research team determined the number of truck parking spaces at each location and recorded total truck parking utilization. During the site visits, the research team also interviewed personnel on-site, including security officers, state troopers, county sheriffs, and the Florida Department of Transportation (FDOT) staff, to obtain their observations about truck parking and assess where illegal truck parking, if any, was occurring. The research team also collected site layout information and explored truck parking patterns and safety issues related to commercial vehicle parking in unauthorized areas on limited access highways. After each site visit, the raw data collected was analyzed to compile a “rest area report” for each of the visited rest areas. This report included brief facility information, truck parking capacity (number of parking spaces), date and time truck counts were taken, actual truck counts, percent utilization, and interview notes summarizing the information gathered from various sources such as truck drivers, on-site security personnel, and FDOT.

The data collection efforts described above enabled the research team to determine the level of truck parking capacity problem experienced at each rest area. This information was used to divide the rest areas into three categories, low, medium, and high, based on the “level of truck parking capacity issues,” and depicted the rest areas on a color-coded map for I-10, I-75, and I-95; green was used for a low parking capacity problem, yellow for a medium parking capacity problem, and red for a high parking capacity problem.

Phase-2 of this research project included an assessment of technology that can be used to improve truck parking management at rest areas in Florida and deploy a pilot project to test implementation. The guiding concept for this research was that providing better information to truck drivers about parking availability can reduce the number of trucks parking on shoulders, crashes due to driver fatigue, and unnecessary diesel emissions.

The vehicle detection technology chosen for the pilot project at the Leon County rest areas (eastbound and westbound) on I-10 features wireless ground sensors, which detect the presence of a vehicle as it comes to a stop above it. The actual occupancy determination is accomplished using a unique combination of differential magnetic induction measurement with a built-in infrared sensor. This combination technology allows the sensors to accurately determine the presence of a high-clearance truck chassis without confusing it with another vehicle parked in an adjacent space. The sensors communicate through a network of wireless mesh repeaters, which relay information to data collectors on the premises. The data collectors in turn are connected to a central database via the Internet. Informational maps, historical data reports, and a number of other applications can be accessed by the user, along with other shared data platforms and devices, such as smart phones.

Over the course of this research, various software tools were developed to complement the wireless vehicle detection system described above, including a GIS mapping application, a report generation module, and an occupancy prediction model. The GIS mapping application developed for the pilot project represents an easy to read site map that offers a real-time feed of the sites’ truck parking information. The report generation module offers immediate access to historical truck parking data collected from the truck parking facilities. The occupancy prediction model

utilizes the Kalman filter to predict available parking spaces at a date and time specified by the user.

# **TABLE OF CONTENTS**

<b>DISCLAIMER</b> .....	ii
<b>APPROXIMATE CONVERSIONS TO SI UNITS</b> .....	iii
<b>TECHNICAL REPORT DOCUMENTATION PAGE</b> .....	iv
<b>EXECUTIVE SUMMARY</b> .....	v
<b>LIST OF TABLES</b> .....	x
<b>LIST OF FIGURES</b> .....	xi

## **CHAPTERS**

<b>1. INTRODUCTION</b> .....	1
1.1 Background .....	1
1.2 Project Objectives .....	1
1.3 Methodology .....	2
<b>2. LITERATURE REVIEW</b> .....	3
2.1 Introduction .....	3
2.2 Previous Research on Rest Areas: <i>Truck parking and vehicle detection technologies</i> ....	3
2.3 Real-Time Tools: <i>Brief Overview</i> .....	7
<b>3. PHASE-1: COMMERCIAL VEHICLE PARKING TRENDS IN FLORIDA</b> .....	10
3.1 Introduction .....	10
3.2 Interstate Segments .....	11
3.3 Data Collected .....	13
3.4 Data Analysis and Reporting .....	14
3.5 I-10 Corridor Rest Area Reports .....	16
3.6 I-10 Corridor Truck Parking Problem Map.....	28
3.7 Photographs Taken at I-10 Corridor Rest Areas .....	29
3.8 I-75 Corridor Rest Area Reports .....	35
3.9 I-75 Corridor Truck Parking Problem Map.....	47
3.10 Photographs Taken at I-75 Corridor Rest Areas .....	48
3.11 I-95 Corridor Rest Area Reports .....	51
3.12 I-95 Corridor Truck Parking Problem Map.....	58
3.13 Photographs Taken at I-95 Corridor Rest Areas .....	59



<b>4. PHASE-2: IMPLEMENTING A SMART PARKING MANAGEMENT SYSTEM FOR COMMERCIAL TRUCKS</b> .....	63
4.1 Introduction .....	63
4.2 Wireless Vehicle Detection System .....	64
4.3 Site Selection and Site Survey .....	67
4.4 System Design and Layout.....	70
4.5 Hardware Installation .....	71
<b>5. GIS MAPPING APPLICATION AND REPORT GENERATION</b> .....	80
5.1 Introduction .....	80
5.2 Network Administration and System Diagnostics .....	80
5.3 Online Access to Software Tools.....	80
5.4 GIS Mapping Application .....	82
5.5 Report Generation .....	85
5.6 Cloud Integration.....	90
<b>6. OCCUPANCY PREDICTION MODEL</b> .....	91
6.1 Introduction to Kalman Filter.....	91
6.2 Applications of Kalman Filter in Intelligent Transportation Systems (ITS).....	92
6.3 Rest Area Occupancy Prediction Model based on Kalman Filter.....	92
6.4 Evaluation of Prediction Accuracy .....	105
6.5 Web-based Occupancy Prediction Query .....	109
<b>7. CONCLUSIONS</b> .....	111
7.1 Summary .....	111
7.2 Advantages of the Tested Wireless Vehicle Detection System.....	112
7.3 Recommendations for Further Research .....	113
<b>REFERENCES</b> .....	115
<b>APPENDIX A: Technical Specifications for Mesh Network Components</b> .....	118
<b>APPENDIX B: Root Mean Squared Error Calculations</b> .....	120

## **LIST OF TABLES**

Table 1: Interstate segments.....	12
Table 2: Leon County rest area information .....	68
Table 3: Average hourly occupancy data for Mondays .....	100
Table 4: Kalman filter iterations .....	103
Table 5: Regression model prediction (example) .....	103
Table 6: The calculated RMSE values.....	107

## **LIST OF FIGURES**

Figure 1: Florida's rest areas .....	10
Figure 2: Segment #7 .....	11
Figure 3: Types of data collected by the research team .....	14
Figure 4: Data analysis and reporting .....	15
Figure 5: I-10 corridor truck parking problem map .....	28
Figure 6: A truck parked on an on-ramp near Tallahassee .....	29
Figure 7: Trucks parked at Holmes County rest area.....	29
Figure 8: Two overflow trucks parked near the exit at Holmes County rest area.....	30
Figure 9: Cramped design of the parking lot at Jackson West.....	30
Figure 10: Illegal parking at Baker East .....	31
Figure 11: Illegal parking at Baker West .....	31
Figure 12: Ruined pavement due to truck parking at Suwannee-Columbia East.....	32
Figure 13: Trucks parked on the access ramp at Madison East .....	33
Figure 14: Illegal parking at Madison West.....	33
Figure 15: Illegal parking at Jefferson West .....	34
Figure 16: I-75 corridor truck parking problem map .....	47
Figure 17: Research team members interviewing a truck driver at the Lee County rest area.....	48
Figure 18: Trucks parked on the shoulder at Columbia South.....	48
Figure 19: Truck parked on the shoulder at Columbia North .....	49
Figure 20: Another truck parked on the shoulder at Columbia North .....	49
Figure 21: The truck parking lot of Alachua North during daytime .....	50
Figure 22: I-95 corridor truck parking problem map .....	58
Figure 23: Trucks parked on the highway shoulder at Brevard North (MM227) .....	59
Figure 24: Trucks parked on the exit ramp and highway shoulder at Brevard North (MM227) .....	59
Figure 25: Trucks parked on the exit ramp at Brevard North (MM227) .....	60
Figure 26: A truck parked on the highway shoulder at Brevard North (MM227) .....	60
Figure 27: A truck parked on the exit ramp at Brevard South (MM227) .....	61
Figure 28: Ruined pavement due to shoulder parking at St. Johns .....	61
Figure 29: Trucks parked on the highway shoulder at St. Johns (MM 302).....	62
Figure 30: Wireless vehicle detection system application at a rest area in Europe .....	64
Figure 31: System components and hardware description.....	65
Figure 32: Top view (left) and bottom view of the ground sensor .....	66
Figure 33: Ground level section view of the sensor.....	66
Figure 34: Leon County rest area outside of Tallahassee, FL.....	68
Figure 35: Leon County rest area (Eastbound) .....	69

Figure 36: Leon County rest area (Westbound).....	69
Figure 37: Leon County rest area system design and layout .....	70
Figure 38: Core drilling process.....	72
Figure 39: The core before removal.....	73
Figure 40: The removed core and the sensor to be installed.....	73
Figure 41: Sensor being installed by the technician.....	74
Figure 42: The first row of sensors after installation .....	75
Figure 43: Relay node mounted to light pole.....	76
Figure 44: Relay node mounted to traffic sign pole.....	77
Figure 45: Data collector mounted to light pole .....	78
Figure 46: Data collector and the camera .....	79
Figure 47: Login screen .....	81
Figure 48: Main menu.....	81
Figure 49: GIS interface.....	82
Figure 50: Camera view (Leon East).....	83
Figure 51: GIS interface in aerial view (Leon East) .....	83
Figure 52: GIS interface in aerial view capturing both rest areas .....	84
Figure 53: Report generation module main menu .....	85
Figure 54: User input screen to generate occupancy reports .....	86
Figure 55: Occupancy report for Leon West (example report).....	86
Figure 56: Average number of trucks parked per day at the Leon County rest areas (example report) .....	87
Figure 57: Average percentage occupancy at Leon West (example report) .....	88
Figure 58: List of parking events at Leon East (example report) .....	89
Figure 59: Hourly truck counts at Leon East (example report) .....	89
Figure 60: Potential integration with SunGuide® .....	90
Figure 61: Kalman filter process.....	96
Figure 62: Standard deviation of historical occupancy data .....	99
Figure 63: Predicted occupancy versus actual occupancy .....	104
Figure 64: Regression curve (example).....	106
Figure 65: RMSE curves.....	108
Figure 66: Web-based occupancy prediction query.....	109
Figure 67: Occupancy prediction report (example) .....	110

# **1. INTRODUCTION**

## **1.1 Background**

Various kinds of freight are relocated daily in and out of Florida through several transportation modes, such as truck, ship, and plane. Among all the modes, trucks move more than 75 percent of tonnage annually, which makes the trucking industry the leader for freight movement in Florida (Cambridge Systematics, 2007). Truck traffic is also expected to grow significantly throughout Florida over the next couple of decades along with the increasing population, globalization of the world economy, and other factors, such as the increased demand for just-in-time deliveries, e-commerce, and less-than-truckload shipping (U.S. DOT, 2000; Fleger et al., 2002).

The combination of increased commercial motor vehicle traffic, tighter delivery schedules, and federally regulated limits on driving time (Hours of Service rules) lead to a nationally recognized problem on interstate highways: increased demand for commercial truck parking. Many states, including Florida, are experiencing a heavy demand for commercial vehicle parking at rest areas, one that exceeds capacity. Several studies have indicated that the inadequacy of parking facilities for commercial trucks may be associated with fatigue-related crashes. In addition, truck drivers who cannot find parking spaces at rest areas often choose to park on entrance and exit ramps, the roadway shoulders, and other unauthorized areas during their required downtime. This is an illegal practice which can affect roadway operations, create unsafe situations, and lead to drop offs, erosion problems, clogging of the drainage system, air pollution, and accelerated deterioration of the pavement (U.S. DOT, 2000; Fleger et al., 2002; NCHRP Synthesis 317, 2003; Smith et al., 2005).

## **1.2 Project Objectives**

The steady growth of commercial truck travel has led to an increasing demand for truck parking spaces at public rest areas on interstate highways in Florida. This research sought to understand the truck parking problem in Florida, determine the supply and demand

characteristics for commercial truck parking, assess technology that can be used to improve parking management, and conduct a pilot project to test a smart truck parking management technology to increase operational efficiency of commercial drivers, reduce trucks parking on shoulders, crashes due to driver fatigue, and unnecessary diesel emissions. The specific objectives of this research included: i) Phase-1: to determine trends for truck parking at rest areas and weigh stations throughout Florida and ii) Phase-2: to develop a suitable smart parking management system for commercial motor vehicles and conduct a pilot project.

### **1.3 Methodology**

This research study was conducted in two phases: Phase-1 and Phase-2.

#### **PHASE-1: Commercial Vehicle Parking Trends in Florida**

To evaluate the adequacy of parking spaces for commercial trucks along interstate highways in Florida and determine the extent of illegal truck parking, information on supply and demand characteristics of commercial truck parking facilities is necessary. Phase-1 of the proposed study inventoried Florida's public rest areas, observed commercial truck parking characteristics, determined current shortfalls in the supply of commercial truck parking spaces, determined illegal parking, and surveyed relevant stakeholders.

#### **PHASE-2: Implementing a Smart Parking Management System for Commercial Trucks**

Two approaches to solving the truck parking shortage include: (i) increasing the supply of parking spaces and (ii) better matching supply and demand in areas where a parking shortage exists. Increasing supply of parking spaces is a direct but also a capital intensive solution, whereas better matching supply and demand is more practical and cost-effective (Smith et al., 2005). Phase-2 of this research project included assessment of technology that can be used to improve truck parking management in Florida by better matching supply and demand at rest areas and deploy a pilot project to test implementation.

## **2. LITERATURE REVIEW**

### **2.1 Introduction**

This chapter provides a comprehensive review of the studies published with regards to commercial vehicle parking at rest areas. The review has been conducted through an investigation into research reports, articles, newsletters, and web-sources. The review is divided into two main parts, keeping in mind the two distinct phases of this research project. The first part provides a detailed account of the research projects and studies that have been conducted over a period of the last three decades. The second part of the literature review discusses the different smart parking technologies currently available.

### **2.2 Previous Research on Rest Areas: *Truck parking and vehicle detection technologies***

The review in this section is provided in chronological form so that the readers can better understand the advancements and intensity of various research efforts conducted over the last three decades.

A study in the State of Michigan (1985) concluded that there were seasonal differences in occupancy times between passengers and heavy vehicles for six rest areas (Twardzik and Haskell, 1985). The Nebraska Department of Roads (1987) also conducted a study that reported the mean time spent in rest areas by vehicle class. King (1989) performed field studies as part of a National Cooperative Highway Research Program (NCHRP) project at nine sites to determine the mean time spent by vehicles at rest areas. Perfater (1989) performed a study to determine operation and motorist usage of interstate rest areas and Welcome Centers in Virginia, compiling limited data on the dwell time of vehicles at 11 rest areas. Other related rest area studies that were conducted include Adams and Reiersen (1981), Melton (1989), and Byrne (1991).

In 1996, the American Transportation Research Institute (ATRI) conducted research to evaluate truck driver rest and parking needs along the National Interstate System by

developing analytical models to estimate the demand for truck parking spaces. The study identified a shortfall of 28,400 truck parking spaces in public rest areas nationwide and predicted the shortage would grow to 39,000 in ten years. The study also concluded that the private truck stops were basically complementary facilities as opposed to a substitute for public rest areas.

The Minnesota Department of Transportation (MnDOT, 1998) performed a commercial truck usage nighttime parking demand analysis for the period of 1995 to 1998. The objective of the study was to identify rest areas where there is a greater demand for nighttime truck parking than there are available spaces and to document the frequency of this occurrence. The study found that there were capacity issues with commercial vehicle parking at 26 safety rest areas in Minnesota out of the 55 full service rest areas operated by MnDOT. At these sites, the nighttime commercial vehicle parking usually was at capacity or exceeded more than 3% of the weekdays or total days per year.

MnDOT conducted a study to determine nighttime commercial vehicle parking demand at 15 high-use Minnesota rest areas. These rest areas were previously identified using the data collected by MnDOT between 1995 and 1998 for oversized vehicles at 50 full-service rest areas around the state. Data was collected each night at 10:00 PM; midnight; 1:00, 2:00, or 3:00 AM depending on the end of shift for custodians; and 6:00, 7:00, or 8:00 AM depending on the start of the new shift for the custodians. The data was used to provide a trend analysis and to project the parking demands by year 2020, as well as to provide some recommendations in the form of future design and data collection considerations (MnDOT, 2001).

Garder and Bosonetto (2002) conducted a study for the New England Transportation Consortium (NETC) focused on finding out the design and operation issues of interstate rest areas in New England. The researchers collected data through surveys to determine usage trends and motorists' preferences. The outcomes of the study suggested that motorists agree to the necessity of the rest areas along the interstates; however, they stressed the need for a well-informed system to assist in deciding the use of rest areas.



The researchers proposed a kiosk system to provide this information to travelers using a GIS interface.

In 2005, the Federal Motor Carrier Safety Administration (FMCSA) began studying truck parking issues and identified two possible solutions to the increasing problem of truck parking capacity at rest areas. One solution is to increase the supply of spaces and better match supply and demand in areas where a parking shortage exists; the other solution was to use Intelligent Transportation Systems (ITS) to develop a system that can provide commercial motor vehicle drivers with real-time parking availability information in order to better match the demand for parking spaces with the existing supply. Since the first solution was capital intensive, a higher degree of recommendation was associated with the ITS solution (Smith et al., 2005). Following its recommendation, in 2007, FMSCA began the smart parking initiative to demonstrate whether ITS applications were a better solution for providing commercial truck drivers with real-time information. Researchers conducted field tests to determine the feasibility of using magnetometry technology, which detects the presence of magnetic metals, to establish parking availability.

Connecticut DOT (2008) conducted a statewide rest area and service plaza study to address the parking issues in facilities such as rest areas and service plazas and provide a comprehensive plan of action. The study was conducted in response to the Federal Highway Administration's (FHWA) initiative to encourage states to develop programs that address the issue. The study involved extensive data collection based on the projected future traveler demands. Furthermore, the study helped in the development of recommendations for improvements to such facilities. One of the important conclusions drawn by the research team was that different modes of transportation have their different service requirements. Therefore, in specific reference to truck parking, it was suggested that trucks and automobiles should have separate parking areas with well-defined pedestrian routes to decrease the possibility of internal conflicts at the sites.

In 2008, the North Jersey Transportation Planning Authority (NJTPA) published a study on truck rest stops. The assessment was done in order to identify potential locations for

truck rest areas in the northern New Jersey and port area. The study found out that a vast majority of the truck drivers encounter a shortage of truck parking facilities, specifically in the case of long overnight parking requirements. As a result, the drivers have to park on the shoulders. The severity of the problem has been emphasized by the fact that nearly 300 trucks were observed on the shoulders of major limited-access highways in the NJTPA region or on local roads in the port area, near rail yards, or adjacent to warehouse and distribution centers during a weekday night (NJTPA, 2008).

Banerjee et al. (2009) undertook a study for CALTRANS to investigate accidents involving driver fatigue near rest areas (and to evaluate methods for reducing them) by conducting a spatial evaluation of fatigue-related collisions. The study made a comparison of normal ramps to those of rest areas' upstream and downstream ramps, and found that trucks were the primary vehicle-type involved in rest area ramp collisions. The study also revealed that some rest areas had too few parking spots, which therefore contributed to the cause of accidents. The study analyzed the collision rates due to the shoulder parking (termed as informal rest areas) and found that such ramps had a higher rate, or greater chance, of collision than other ramps.

Al-Kaisy et al. (2010) conducted a study collecting and analyzing dwell time data from three rest areas in Montana. They utilized surveillance cameras attached to high-mast mobile trailers. These cameras were powered with solar panels, and the mobile trailers were deployed for one week at each study site. Manual processing of the field dwell time data was utilized in this study.

Finally, Gates et al. (2012) conducted a study for the Michigan Department of Transportation (MDOT) to determine the value of public rest areas, including Welcome Centers, in Michigan. The researchers performed a benefit-cost analysis to determine the economic feasibility of the rest areas in the Michigan interstate system. The B/C analysis was performed both at the individual rest area, as well as the system, level. The results of the economic analysis showed that nearly all MDOT rest areas currently possess B/C ratios that exceed 1.0, while the system of rest areas in the state was also found extremely

feasible with a B/C ratio of 4.56. The individual values for the 81 facilities ranged from between 0.78 to 11.66. Most of the rest area benefits came through comfort/convenience (i.e., the “value” to users), or reduction of targeted fatigue-related crashes and tourism benefits (Welcome Centers only). The researchers also developed a software tool to allow for the estimation of impacts associated with the removal of rest area(s) from the system.

### **2.3 Real-Time Tools: *Brief Overview***

This section discusses technologies and approaches related to i) available vehicle detection technologies, ii) occupancy calculation methods, and iii) forecasting space availability.

#### **Available Vehicle Detection Technologies**

The literature review indicates that a wide range of intrusive and non-intrusive technologies have been successfully introduced or proposed in practice to obtain the basic input data for parking systems, such as: (1) inductive loop detector, (2) magnetic sensor, (3) ultrasonic sensor, (4) infrared sensor, and (5) machine vision (video image processor). Havinoviski et al. (2000) considered which specific data collection technologies were the most practical for different scenarios:

- In-garage information: infrared sensor;
- Surface lot information: inductive loop detector or ultrasonic sensor; and
- Wide-area parking information: video image processing.

#### **Occupancy Calculation Methods**

There are essentially two approaches in using automation to determine how many spaces are available at a particular parking area (Smith et al. 2005).

- **Individual Parking Bay Detection:** Either sensors are installed in each parking space or a video pattern recognition system is used to count available spaces. While this approach offers accuracy, it is more costly with respect to equipment and installation (Smith et al. 2005).

- **Count In and Count Out:** This method includes counting of the number of trucks entering and exiting a parking area using a sensor and, subsequently, calculation of the number of vehicles currently parked (Smith et al. 2005). As quoted from Smith et al. (2005), “this usually produces less accurate results because not all vehicles will park in a designated space, some vehicles will take up multiple spaces, and a sensor misread may never be corrected unless the parking area closes periodically or a manual count and correction is performed.”

### **Forecasting Space Availability**

Smith et al. (2005) indicates: “Even a perfectly accurate parking occupancy detection system will only indicate the number of spaces available at a particular point in time. What the drivers need, however, is an indication of whether spaces will be available at the time he or she arrives at the truck stop or rest area.” The study lists the following quoted approaches to deal with this problem:

- “Furnish information to the driver just before the entry to the rest area or truck stop. With a less than 1-minute lag, the actual occupancy number is not likely to change significantly. However, this does not help a driver to choose among rest locations, since some of them may be many miles down the road” (Smith et al. 2005).
- “Furnish information on the number of spaces occupied and the number of spaces available, and let drivers do their own estimating as to whether spaces will be available when they arrive. This may be sufficient for a driver who is familiar with the corridor, but may not be helpful to an unfamiliar driver” (Smith et al. 2005).
- “Provide a forecast of space availability, based on historical information.” For example: if 20 spaces are open now at 7:00 PM, the lot will likely be full by 8:00 PM (Smith et al. 2005).

- “Allow drivers to send an inquiry or request for parking to the parking management system, and incorporate this request along with requests from other drivers into the forecasts” (Smith et al. 2005).

### 3. PHASE-1: COMMERCIAL VEHICLE PARKING TRENDS IN FLORIDA

#### 3.1 Introduction

Phase-1 of this research project included an evaluation of the commercial vehicle parking trends at public rest areas in Florida (Figure 1). The major objective of this analysis was to assess the adequacy of public parking spaces for commercial trucks along interstate highways in Florida, identify facilities that reach or are over capacity during the busiest hours of the day (usually nighttime hours), and determine the extent of illegal truck parking.



- ❑ FDOT operates 53 rest areas at 35 sites
- ❑ Generally located 45 minutes traveling time apart

Figure 1: Florida's rest areas  
(Source: FDOT)

The specific objectives of Phase-1 included: (i) to determine the supply characteristics of public truck parking facilities along interstate highways in Florida; (ii) to determine the demand characteristics of facilities along interstate highways in Florida; (iii) to determine public truck parking facilities that are being used and to what capacity; and (iv) to determine current shortfalls in the supply of commercial truck parking spaces along interstate highways in Florida.

### 3.2 Interstate Segments

Phase-1 involved collection of field observation data by the research team at all of the public rest areas along the I-10, I-75, and I-95 corridors. In order to manage the data collection process effectively, the research team defined seven (7) segments on the Interstate System which typically included three to five consecutive public rest areas (Table 1). For example, the Broward, Collier, Lee, and Charlotte rest areas on the south section of I-75 constitute one such segment, Segment #7, with a length of about 127 miles (Figure 2). The research team drove along these segments during nighttime over a two-to-three-day period per segment, and visited each facility in the segment at least once per night to collect data regarding its supply and demand characteristics.



Figure 2: Segment #7

**Table 1: Interstate segments**

Facility Number	Type	County/District	Interstate Number	Mile Marker	Distance from Previous Facility (mi.)	Segment Length (mi.)
<b>SEGMENT 1 (I-10 WEST)</b>						
30651	RA	Escambia/3	10	4	N/A	158
30031	RA	Santa Rosa/3	10	29	25	
30041	RA	Okaloosa/3	10	58	29	
30050	RA	Holmes/3	10	96	38	
30061	RA	Jackson/3	10	133	37	
30070	RA	Gadsden/3	10	162	29	
<b>SEGMENT 2 (I-10 EAST)</b>						
30081	RA	Leon/3	10	194	N/A	124
30091	RA	Jefferson/3	10	233	39	
20101	RA	Madison/2	10	265	32	
20111	RA	Suwan.-Columbia/2	10	294	29	
20121	RA	Baker/2	10	318	24	
<b>SEGMENT 3 (I-75 NORTH)</b>						
20622	RA	Hamilton/2	75	470	N/A	141
20162	RA	Columbia/2	75	413	57	
20172	RA	Alachua/2	75	382	31	
50182	RA	Marion/5	75	346	36	
50192	RA	Sumter/5	75	308	30	
<b>SEGMENT 4 (I-95 NORTH)</b>						
20611	RA	Nassau/2	95	378	N/A	90
20331	RA	St. Johns/2	95	331	47	
20321	RA	St. Johns/2	95	302	29	



**Table 1: Interstate segments (continued)**

Facility Number	Type	County/District	Interstate Number	Mile Marker	Distance from Previous Facility (mi.)	Segment Length (mi.)
<b>SEGMENT 5 (I-95 SOUTH)</b>						
40401	RA	Brevard/5	95	227	N/A	120
40391	RA	Brevard/5	95	169	26	
50381	RA	St. Lucie/4	95	133	36	
50341	RA	Martin/4	95	107	58	
<b>SEGMENT 6 (I-75 CENTRAL)</b>						
70251	RA	Hillsborough/7	75	238	N/A	N/A
10370	RA	Manatee/1	275	7	N/A	
70360	RA	Pinellas/7	275	13	N/A	
70241	RA	Pasco/7	75	Closed	N/A	
<b>SEGMENT 7 (I-75 SOUTH)</b>						
40490	RA	Charlotte/1	75	161	N/A	127
10290	RA	Lee/1	75	131	30	
10280	RA	Collier/1	75	63	68	
10270	RA	Broward/4	75	34	29	

### 3.3 Data Collected

The research team determined the number of truck parking spaces at each location and recorded total truck parking utilization. Total parking utilization is the percentage of trucks parked both legally in the parking spaces and illegally elsewhere at the facility with respect to the available capacity. For example, if a rest area has 18 parking spaces, and at 1:00 AM it has 18 trucks parked legally, as well as 3 trucks parked at the entrance and 4 trucks parked at the exit, this yields a total of 25 trucks parked at the location, resulting in a 139% utilization ratio for the site at 1:00 AM.

During the site visits, the research team also interviewed personnel on-site, including security officers, state troopers, county sheriffs, and the Florida Department of

Transportation (FDOT) staff, to obtain their observations about truck parking and assess where illegal truck parking, if any, was occurring. The research team also collected site layout information and explored truck parking patterns and safety issues in unauthorized areas on limited access highways (Figure 3).

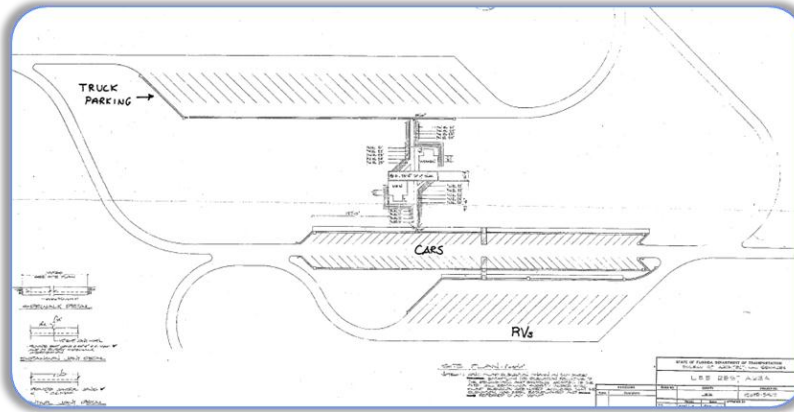

Site Layout Information



Documentation of Illegal Parking

FDOT Project-Commercial Motor Vehicle Parking trends at Rest areas and Weigh Stations

Rest Area Name	Hillsborough NORTH (I-75 mile marker 238)	
Direction/Location	NORTH (May 18, 2011)	
Date	WEDNESDAY MORNING SHIFT (MIDNIGHT-8 AM) 15	
	Time	Number of Trucks
Cap. of regular truck lot = 18 Unofficial parking in RV lot + parking on ramps	Midnight	17 - regular truck lot 12 - Ramps TOTAL = 39
	2:00 AM	17 - regular truck lot 2 - RV lot 12 - Ramps Total = 43
	4:00 AM	15 - regular truck lot 8 - RV lot 14 - Ramps Total = 43
	6:00 AM	14 - regular truck lot 4 - RV lot 16 - Ramps Total = 34
	8:00 AM	12 - regular truck lot 1 - RV lot 7 - Ramps Total = 23

Truck Parking Data Collection Form



Interviews

Figure 3: Types of data collected by the research team

### 3.4 Data Analysis and Reporting

After each site visit, the raw data collected was analyzed to compile a “rest area report” for each of the visited rest areas. This report included brief facility information, truck parking capacity (number of parking spaces), date and time truck counts were taken, actual truck counts, percent utilization, and interview notes summarizing the information

gathered from various sources such as truck drivers, on-site security personnel, and FDOT (Figure 4).

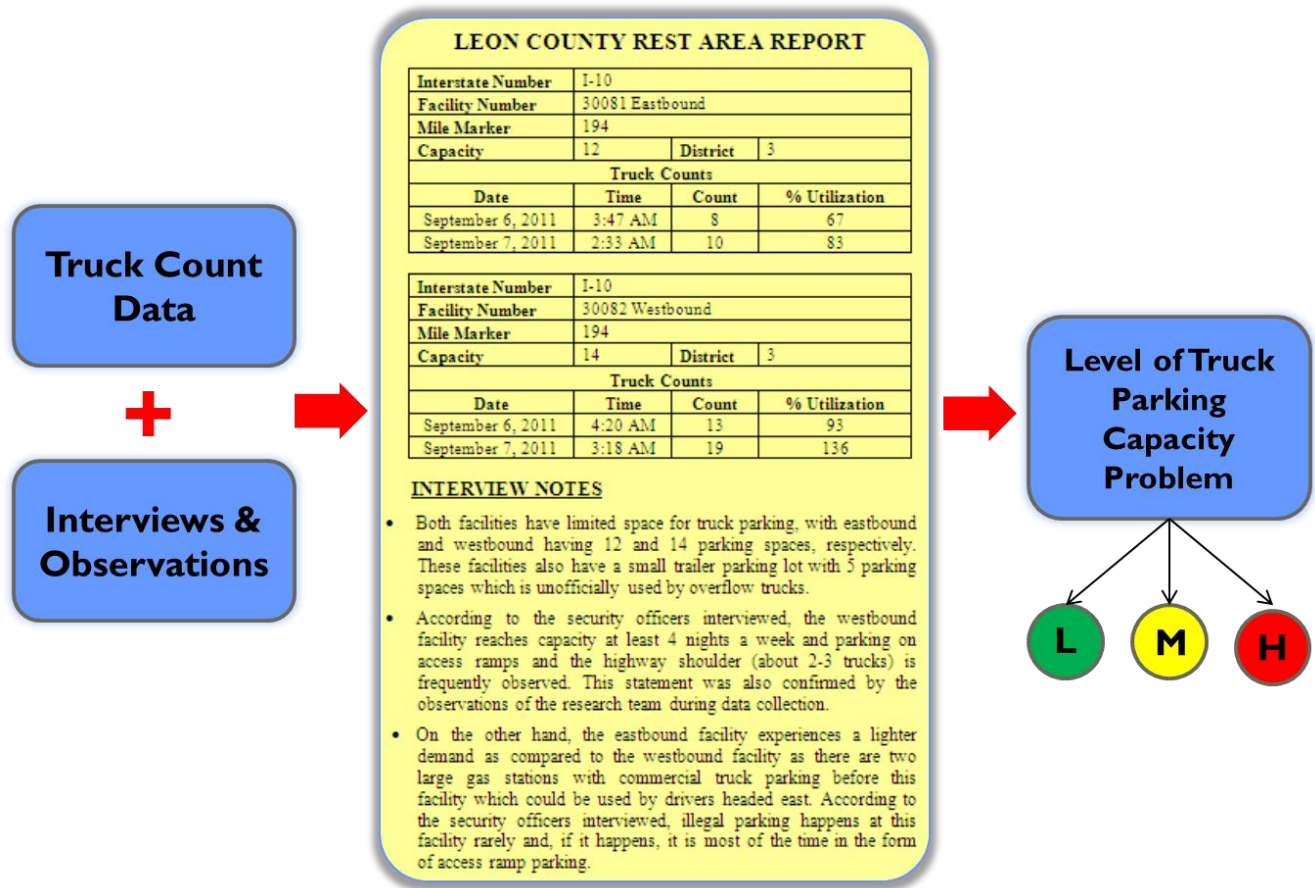

**Figure 4: Data analysis and reporting**

The data collection efforts described above enabled the research team to determine the level of truck parking capacity problem experienced at each rest area. This information was used to divide the rest areas into three categories, low, medium, and high, based on the “level of truck parking capacity problem,” and depicted the rest areas on a color-coded map for I-10, I-75, and I-95; green was used for a low parking capacity problem, yellow for a medium parking capacity problem, and red for a high parking capacity problem. The following three sections of this chapter present the rest area reports for each visited facility, the resulting color-coded map for the I-10, I-75, and I-95 corridors, and the relevant photographs taken during the visits documenting illegal parking in these corridors.

### 3.5 I-10 Corridor Rest Area Reports

#### ESCAMBIA COUNTY WELCOME CENTER

##### Truck Counts

<b>Interstate Number</b>	I-10		
<b>Facility Number</b>	30010		
<b>Mile Marker</b>	4		
<b>Capacity</b>	31	<b>District</b>	3
<b>Truck Counts</b>			
<b>Date</b>	<b>Time</b>	<b>Count</b>	<b>% Utilization</b>
September 8, 2011	3:25 AM	29	94
September 9, 2011	2:50 AM	24	77

##### Notes

- The security officer indicated that, although the truck parking lot operates at near capacity about four (4) nights a week, there is no significant truck parking problem at this facility, as it never gets packed except during Christmas time.
- The security officer also indicated that no illegal parking is allowed at this facility; thus, if there are no parking spaces available, truck drivers will simply keep moving as most drivers know that rest areas in Santa Rosa or Okaloosa County typically have spaces available. Nevertheless, curbside parking is occasionally observed, and less frequently, access ramp parking.
- A weigh station is located only one mile before this facility east on I-10, which could be used (or better utilized) by truck drivers for nighttime parking. Although a common issue in Florida, this problem (i.e., the hesitation of truck drivers to use weigh stations for nighttime parking) requires attention if the parking capacity problem at rest areas is to be managed more effectively.

## SANTA ROSA COUNTY REST AREA

### Truck Counts

<b>Interstate Number</b>	I-10		
<b>Facility Number</b>	30031 Eastbound		
<b>Mile Marker</b>	29		
<b>Capacity</b>	75	<b>District</b>	3
<b>Truck Counts</b>			
<b>Date</b>	<b>Time</b>	<b>Count</b>	<b>% Utilization</b>
September 8, 2011	3:55 AM	47	63
September 9, 2011	3:27 AM	39	52

<b>Interstate Number</b>	I-10		
<b>Facility Number</b>	30032 Westbound		
<b>Mile Marker</b>	29		
<b>Capacity</b>	75	<b>District</b>	3
<b>Truck Counts</b>			
<b>Date</b>	<b>Time</b>	<b>Count</b>	<b>% Utilization</b>
September 8, 2011	2:40 AM	63	84
September 9, 2011	2:00 AM	58	77

### Notes

- The eastbound and westbound facilities at this rest area are fairly new (built in 2004) with a relatively high truck parking capacity.
- According to the security officers interviewed, due to the high capacity, both facilities can typically accommodate the truck parking demand very well and rarely reach full capacity (a couple of truck parking spaces are usually left).

## OKALOOSA COUNTY REST AREA

### Truck Counts

<b>Interstate Number</b>	I-10		
<b>Facility Number</b>	30041 Eastbound		
<b>Mile Marker</b>	58		
<b>Capacity</b>	47	<b>District</b>	3
<b>Truck Counts</b>			
<b>Date</b>	<b>Time</b>	<b>Count</b>	<b>% Utilization</b>
September 8, 2011	4:25 AM	35	75
September 9, 2011	4:05 AM	33	70

<b>Interstate Number</b>	I-10		
<b>Facility Number</b>	30042 Westbound		
<b>Mile Marker</b>	61		
<b>Capacity</b>	47	<b>District</b>	3
<b>Truck Counts</b>			
<b>Date</b>	<b>Time</b>	<b>Count</b>	<b>% Utilization</b>
September 8, 2011	6:00 AM	43	92
September 9, 2011	4:20 AM	40	85

### Notes

- The security officers indicated that the westbound facility is busier than the eastbound facility as it is the first option for truck drivers headed west on I-10 before the Santa Rosa County rest area and the Escambia County Welcome Center; for drivers headed east, the Okaloosa eastbound facility becomes the third option after these two rest areas.
- The westbound truck parking lot typically operates at or above capacity about four (4) nights a week, with occasional illegal parking on the access ramps and highway shoulder. On the other hand, the eastbound facility does not reach capacity more than a few nights per month, with an average nighttime utilization of around 75%.

## HOLMES COUNTY REST AREA

### Truck Counts

<b>Interstate Number</b>	I-10		
<b>Facility Number</b>	30050 Eastbound/Westbound		
<b>Mile Marker</b>	96		
<b>Capacity</b>	12	<b>District</b>	3
<b>Truck Counts</b>			
<b>Date</b>	<b>Time</b>	<b>Count</b>	<b>% Utilization</b>
September 8, 2011	5:10 AM	14	117
September 9, 2011	4:50 AM	15	125

### Notes

- This rest area has a small truck parking lot with only 12 spaces available. It is also one of the oldest rest areas on I-10. This facility experiences a high level of truck parking capacity problem. According to the security officer interviewed, the parking lot operates overcapacity most nights of the week.
- The research team observed that various undesignated spaces within the commercial vehicle parking lot were being used by overflow trucks. Also, a couple of trucks were observed to enter the facility, but were forced to leave due to the unavailability of truck parking spaces. The security officer indicated that 7 to 10 trucks on average are turned down in a typical night due to the unavailability of parking spaces.

## JACKSON COUNTY REST AREA

### Truck Counts

<b>Interstate Number</b>	I-10		
<b>Facility Number</b>	30061 Eastbound		
<b>Mile Marker</b>	133		
<b>Capacity</b>	8	<b>District</b>	3
<b>Truck Counts</b>			
<b>Date</b>	<b>Time</b>	<b>Count</b>	<b>% Utilization</b>
September 6, 2011	2:30 AM	9	113
September 7, 2011	1:20 AM	13	163

<b>Interstate Number</b>	I-10		
<b>Facility Number</b>	30062 Westbound		
<b>Mile Marker</b>	133		
<b>Capacity</b>	11	<b>District</b>	3
<b>Truck Counts</b>			
<b>Date</b>	<b>Time</b>	<b>Count</b>	<b>% Utilization</b>
September 6, 2011	2:13 AM	11	100
September 7, 2011	1:00 AM	17	155

### Notes

- Both facilities have very limited space for truck parking, with eastbound and westbound having only 8 and 11 truck parking spaces, respectively. The westbound facility has a trailer parking lot, which is unofficially used by overflow trucks. According to the security officers interviewed, both facilities reach capacity at least five (5) nights a week.
- The research team observed trucks parked on the entrance ramp and in various undesignated spaces within the parking lot at the eastbound facility. The westbound facility has truck parking stalls designed for 48-foot trailers, which make it very difficult for truck drivers to maneuver around, especially when the lot is at near-capacity.



## GADSDEN COUNTY REST AREA

### Truck Counts

<b>Interstate Number</b>	I-10		
<b>Facility Number</b>	30070 Eastbound/Westbound		
<b>Mile Marker</b>	162		
<b>Capacity</b>	41	<b>District</b>	3
<b>Truck Counts</b>			
<b>Date</b>	<b>Time</b>	<b>Count</b>	<b>% Utilization</b>
September 6, 2011	1:30 AM	24	59
September 7, 2011	1:57 AM	33	81

### Notes

- According to the security officers interviewed, although this rest area may reach capacity one or two (1-2) times a week, it does not experience a significant truck parking capacity problem; most nights enough parking space is available to trucks, thus illegal parking is rarely observed.
- During the two nighttime visits, the research team did not observe the facility reaching capacity.

## LEON COUNTY REST AREA

### Truck Counts

<b>Interstate Number</b>	I-10		
<b>Facility Number</b>	30081 Eastbound		
<b>Mile Marker</b>	194		
<b>Capacity</b>	13	<b>District</b>	3
<b>Truck Counts</b>			
<b>Date</b>	<b>Time</b>	<b>Count</b>	<b>% Utilization</b>
September 6, 2011	3:47 AM	8	62
September 7, 2011	2:33 AM	10	77

<b>Interstate Number</b>	I-10		
<b>Facility Number</b>	30082 Westbound		
<b>Mile Marker</b>	194		
<b>Capacity</b>	13	<b>District</b>	3
<b>Truck Counts</b>			
<b>Date</b>	<b>Time</b>	<b>Count</b>	<b>% Utilization</b>
September 6, 2011	4:20 AM	13	100
September 7, 2011	3:18 AM	19	146

### Notes

- Both facilities have limited space for truck parking. These facilities also have a small trailer parking lot with 5 parking spaces, which is used by overflow trucks.
- According to the security officers interviewed, the westbound facility reaches capacity often during weekdays, and parking on access ramps and the highway shoulder (about 2-3 trucks) is frequently observed. This statement was also confirmed by the observations of the research team during data collection.
- On the other hand, compared to the westbound facility, the eastbound facility experiences a lighter demand due to the two large gas stations with commercial truck parking which are positioned before this facility and could be used by drivers headed east. According to the security officers interviewed, while illegal parking rarely occurs at this facility, if it happens, it will occur along the access ramps.

## JEFFERSON COUNTY REST AREA

### Truck Counts

<b>Interstate Number</b>	I-10		
<b>Facility Number</b>	30091 Eastbound		
<b>Mile Marker</b>	233		
<b>Capacity</b>	21	<b>District</b>	3
<b>Truck Counts</b>			
<b>Date</b>	<b>Time</b>	<b>Count</b>	<b>% Utilization</b>
August 4, 2011	1:43 AM	18	86
August 5, 2011	1:25 AM	20	95

<b>Interstate Number</b>	I-10		
<b>Facility Number</b>	30092 Westbound		
<b>Mile Marker</b>	233		
<b>Capacity</b>	22	<b>District</b>	3
<b>Truck Counts</b>			
<b>Date</b>	<b>Time</b>	<b>Count</b>	<b>% Utilization</b>
August 4, 2011	1:17 AM	17	77
August 5, 2011	12:48 AM	18	82

### Notes

- According to the security officers interviewed, both facilities reach capacity at least three to four (3-4) nights a week.
- The major problem at both facilities is that the truck parking stalls were designed for 48-foot trailers, whereas 53-foot trailers are predominantly used today. Hence, the current layout makes it very difficult for truck drivers to maneuver around, especially when the lot is at near-capacity. According to the security officers, because of this issue, the truck parking lots at both facilities get “cramped” and cannot be utilized at capacity.

- During the site visits, the research team observed that, due to the problem mentioned above, some truck drivers chose to park on access ramps at both facilities, although the truck parking lot was not at full capacity.

## MADISON COUNTY REST AREA

### Truck Counts

<b>Interstate Number</b>	I-10		
<b>Facility Number</b>	20101 Eastbound		
<b>Mile Marker</b>	265		
<b>Capacity</b>	20	<b>District</b>	2
<b>Truck Counts</b>			
<b>Date</b>	<b>Time</b>	<b>Count</b>	<b>% Utilization</b>
August 4, 2011	2:18 AM	13	65
August 5, 2011	1:53 AM	15	75

<b>Interstate Number</b>	I-10		
<b>Facility Number</b>	20102 Westbound		
<b>Mile Marker</b>	265		
<b>Capacity</b>	17	<b>District</b>	2
<b>Truck Counts</b>			
<b>Date</b>	<b>Time</b>	<b>Count</b>	<b>% Utilization</b>
August 4, 2011	6:20 AM	12	71
August 5, 2011	5:58 AM	13	77

### Notes

- As indicated by the security officers interviewed, the eastbound and westbound facilities at this rest area do not experience a significant truck parking capacity problem. The truck parking lot at both facilities may reach capacity one to two (1-2) nights a week, but there are usually a few spaces left in the truck parking lot. Accordingly, illegal truck parking is not a concern at this rest area.

## SUWANNEE/COLUMBIA COUNTY REST AREA

### Truck Counts

<b>Interstate Number</b>	I-10		
<b>Facility Number</b>	20111 Eastbound		
<b>Mile Marker</b>	294		
<b>Capacity</b>	14	<b>District</b>	2
<b>Truck Counts</b>			
<b>Date</b>	<b>Time</b>	<b>Count</b>	<b>% Utilization</b>
August 4, 2011	2:47 AM	12	86
August 5, 2011	2:27 AM	16	114

<b>Interstate Number</b>	I-10		
<b>Facility Number</b>	20112 Westbound		
<b>Mile Marker</b>	295		
<b>Capacity</b>	14	<b>District</b>	2
<b>Truck Counts</b>			
<b>Date</b>	<b>Time</b>	<b>Count</b>	<b>% Utilization</b>
August 4, 2011	4:53 AM	18	129
August 5, 2011	4:37 AM	15	107

### Notes

- The security officers interviewed indicated that both facilities at this rest area operate at or above capacity almost every weeknight. The research team has observed illegal parking on access ramps and highway shoulders at both facilities.

## BAKER COUNTY REST AREA

### Truck Counts

<b>Interstate Number</b>	I-10		
<b>Facility Number</b>	20111 Eastbound		
<b>Mile Marker</b>	294		
<b>Capacity</b>	21	<b>District</b>	2
<b>Truck Counts</b>			
<b>Date</b>	<b>Time</b>	<b>Count</b>	<b>% Utilization</b>
August 4, 2011	3:38 AM	23	110
August 5, 2011	3:25 AM	26	124

<b>Interstate Number</b>	I-10		
<b>Facility Number</b>	20112 Westbound		
<b>Mile Marker</b>	295		
<b>Capacity</b>	21	<b>District</b>	2
<b>Truck Counts</b>			
<b>Date</b>	<b>Time</b>	<b>Count</b>	<b>% Utilization</b>
August 4, 2011	4:18 AM	22	105
August 5, 2011	4:02 AM	24	114

### Notes

- Both facilities at this rest area have a very high-level truck parking capacity problem. The research team has observed illegal parking on access ramps and highway shoulders at both facilities.

### 3.6 I-10 Corridor Truck Parking Problem Map

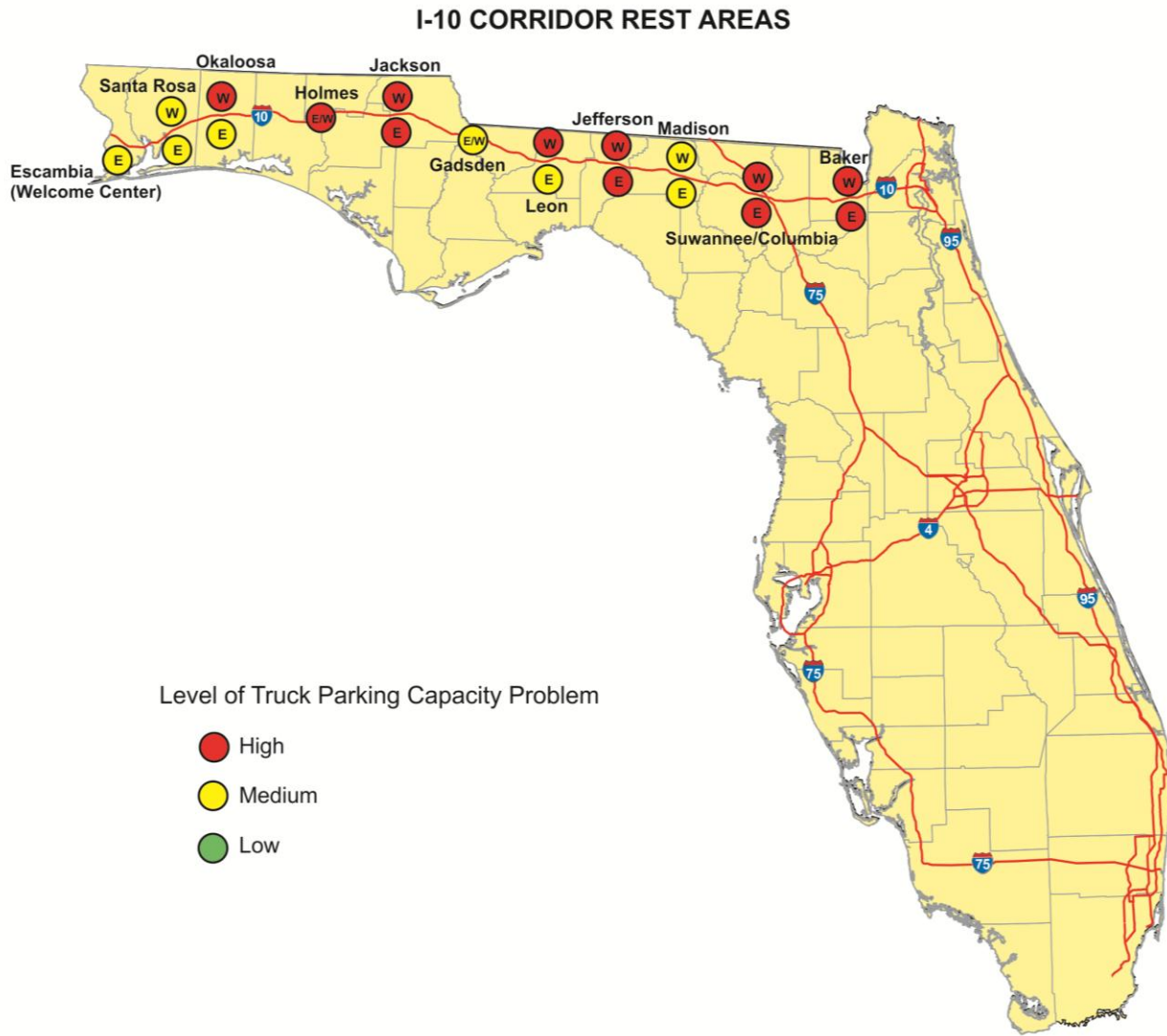

Figure 5: I-10 corridor truck parking problem map



### 3.7 Photographs Taken at I-10 Corridor Rest Areas



**Figure 6: A truck parked on an on-ramp near Tallahassee. The research team observed this type of illegal parking at many on-ramps along I-10.**



**Figure 7: Trucks parked at Holmes County rest area**



**Figure 8: Two overflow trucks parked near the exit at Holmes County rest area**



**Figure 9: The cramped design of the parking lot at Jackson West makes it difficult for trucks to get in and out during nighttime**



**Figure 10: Illegal parking at Baker East**



**Figure 11: Illegal parking at Baker West**





**Figure 12: Ruined pavement due to truck parking at Suwannee-Columbia East**





**Figure 13: Trucks parked on the access ramp at Madison East**



**Figure 14: Illegal parking at Madison West**



**Figure 15: Illegal parking at Jefferson West**

### 3.8 I-75 Corridor Rest Area Reports

#### HAMILTON COUNTY WELCOME CENTER

##### Truck Counts

<b>Interstate Number</b>	I-75		
<b>Facility Number</b>	20140		
<b>Mile Marker</b>	470		
<b>Capacity</b>	38	<b>District</b>	2
<b>Truck Counts</b>			
<b>Date</b>	<b>Time</b>	<b>Count</b>	<b>% Utilization</b>
August 4, 2011	5:32 AM	39	103
August 5, 2011	5:10 AM	42	111

##### Notes

- The security officer indicated that the truck parking lot at this facility operates at or above capacity almost every weeknight.
- The research team did not observe any illegal parking on access ramps or the highway shoulder. The overflow trucks were parked in various undesignated spaces within the commercial vehicle parking lot.

## COLUMBIA COUNTY REST AREA

### Truck Counts

<b>Interstate Number</b>	I-75		
<b>Facility Number</b>	20161 Northbound		
<b>Mile Marker</b>	413		
<b>Capacity</b>	49	<b>District</b>	2
<b>Truck Counts</b>			
<b>Date</b>	<b>Time</b>	<b>Count</b>	<b>% Utilization</b>
August 2, 2011	2:27 AM	41	84
August 3, 2011	1:50 AM	54	110

<b>Interstate Number</b>	I-75		
<b>Facility Number</b>	20162 Southbound		
<b>Mile Marker</b>	413		
<b>Capacity</b>	49	<b>District</b>	2
<b>Truck Counts</b>			
<b>Date</b>	<b>Time</b>	<b>Count</b>	<b>% Utilization</b>
August 2, 2011	2:48 AM	51	104
August 3, 2011	2:05 AM	50	102

### Notes

- Both facilities reach capacity at some point during nighttime almost every weeknight; however, weekends are usually better.
- According to the security officer interviewed, illegal parking is observed quite often at both facilities. As construction is ongoing at both facilities, truck drivers are currently prevented from parking on the access ramps of the rest area.



**ALACHUA COUNTY REST AREA**

**Truck Counts**

<b>Interstate Number</b>	I-75		
<b>Facility Number</b>	20171 Northbound		
<b>Mile Marker</b>	383		
<b>Capacity</b>	7	<b>District</b>	2
<b>Truck Counts</b>			
<b>Date</b>	<b>Time</b>	<b>Count</b>	<b>% Utilization</b>
August 2, 2011	1:50 AM	10	143
August 3, 2011	1:20 AM	8	114

<b>Interstate Number</b>	I-75		
<b>Facility Number</b>	20172 Southbound		
<b>Mile Marker</b>	382		
<b>Capacity</b>	13	<b>District</b>	2
<b>Truck Counts</b>			
<b>Date</b>	<b>Time</b>	<b>Count</b>	<b>% Utilization</b>
August 2, 2011	3:30 AM	16	123
August 3, 2011	2:37 AM	14	108

**Notes**

- Both facilities have very limited space for truck parking, with northbound and southbound having only 7 and 13 truck parking spaces, respectively.
- During the site visits, many trucks were observed that entered the facility but had to leave due to the unavailability of truck parking space. According to the security officer interviewed, illegal parking on access ramps is often observed at both facilities.

## MARION COUNTY REST AREA

### Truck Counts

<b>Interstate Number</b>	I-75		
<b>Facility Number</b>	50181 Northbound		
<b>Mile Marker</b>	345		
<b>Capacity</b>	47	<b>Districts</b>	5
<b>Truck Counts</b>			
<b>Date</b>	<b>Time</b>	<b>Count</b>	<b>% Utilization</b>
August 2, 2011	6:00 AM	28	60
August 3, 2011	12:40 AM	21	45

<b>Interstate Number</b>	I-75		
<b>Facility Number</b>	50182 Southbound		
<b>Mile Marker</b>	346		
<b>Capacity</b>	45	<b>Districts</b>	5
<b>Truck Counts</b>			
<b>Date</b>	<b>Time</b>	<b>Count</b>	<b>% Utilization</b>
August 2, 2011	4:00 AM	46	102
August 2, 2011	10:25 PM	22	49

### Notes

- Both facilities have a trailer parking lot to accommodate excess truck parking demand. These lots can hold from 20 to 25 trucks.
- The regular truck parking lot in the southbound facility reaches capacity during weeknights, whereas the northbound reaches capacity only one or two (1-2) nights a week.
- The security officers in both facilities indicated that they rarely, maybe two or three nights per month, see both the regular truck and trailer lot full. Due to the extra capacity from the trailer lot, illegal parking is less likely to occur at these facilities.

## SUMTER COUNTY REST AREA

### Truck Counts

<b>Interstate Number</b>	I-75		
<b>Facility Number</b>	50191 Northbound		
<b>Mile Marker</b>	307 Northbound		
<b>Capacity</b>	44	<b>District</b>	5
<b>Truck Counts</b>			
<b>Date</b>	<b>Time</b>	<b>Count</b>	<b>% Utilization</b>
August 2, 2011	5:05 AM	44	100
August 3, 2011	12:10 AM	40	91

<b>Interstate Number</b>	I-75		
<b>Facility Number</b>	50192 Southbound		
<b>Mile Marker</b>	308 Southbound		
<b>Capacity</b>	34	<b>District</b>	5
<b>Truck Counts</b>			
<b>Date</b>	<b>Time</b>	<b>Count</b>	<b>% Utilization</b>
August 2, 2011	4:45 AM	37	109
August 2, 2011	11:30 PM	30	88

### Notes

- The southbound facility has a trailer parking lot which is used to accommodate excess truck parking demand. This lot is smaller than the trailer parking lots at the Marion County facilities, holding from 10 to 12 trucks. The northbound facility, however, does not have a trailer parking lot.
- According to the security officers interviewed, both facilities get packed between 1:00 and 4:00 AM at least three to four (3-4) nights a week, including the trailer parking lot in the southbound facility.
- The security officers indicated that the current closure of the Pasco County rest area placed extra demand on these facilities. They expect the demand to go down once the Pasco County rest area reopens.

## HILLSBOROUGH COUNTY REST AREA

### Truck Counts

<b>Interstate Number</b>	I-75		
<b>Facility Number</b>	70251 Northbound		
<b>Mile Marker</b>	238		
<b>Capacity</b>	18	<b>District</b>	7
<b>Truck Counts</b>			
<b>Date</b>	<b>Time</b>	<b>Count</b>	<b>% Utilization</b>
May 17, 2011	11:30 PM	29	161
May 18, 2011	2:00 AM	43	239
May 19, 2011	4:00 AM	34	189
May 20, 2011	1:00 AM	30	167

<b>Interstate Number</b>	I-75		
<b>Facility Number</b>	70252 Southbound		
<b>Mile Marker</b>	238		
<b>Capacity</b>	43	<b>District</b>	7
<b>Truck Counts</b>			
<b>Date</b>	<b>Time</b>	<b>Count</b>	<b>% Utilization</b>
May 18, 2011	4:00 AM	30	70
May 19, 2011	6:00 AM	27	63
May 20, 2011	2:00 AM	28	65

### Notes

- According to the security officers interviewed, the northbound facility is packed almost every weeknight between 10:00 PM and 6:00 AM, whereas the southbound facility gets busy mostly on Sunday and Monday nights. The northbound facility also has a trailer parking lot that can accommodate about 15 trucks. The southbound facility is newer than the northbound facility and can accommodate more trucks in the regular truck parking lot.
- The research team observed a high amount of parking activity on access ramps in the northbound facility.
- The security officers indicated that when the Pasco County rest area was open, there was less demand for the Hillsborough County rest area.

## PINELLAS COUNTY REST AREA

### Truck Counts

<b>Interstate Number</b>	I-275		
<b>Facility Number</b>	70360		
<b>Mile Marker</b>	13		
<b>Capacity</b>	20	<b>District</b>	7
<b>Truck Counts</b>			
<b>Date</b>	<b>Time</b>	<b>Count</b>	<b>% Utilization</b>
May 19, 2011	2:00 AM	4	20
May 20, 2011	4:00 AM	6	30
May 21, 2011	12:30 AM	3	15

### Notes

- This rest area is located at the north end of the Skyway bridge. Its truck parking capacity is on the low side with 20 truck parking spaces available. This rest area mainly serves passenger cars and experiences low truck traffic.
- The security officer who has experience with the Pinellas County, Hillsborough County, and Pasco County rest areas indicated that the Pinellas County rest area has no problem with truck parking (due to low demand) whereas the Hillsborough County and Pasco County (currently closed) rest areas have a severe capacity problem.

## MANATEE COUNTY REST AREA

### Truck Counts

<b>Interstate Number</b>	I-275		
<b>Facility Number</b>	10370		
<b>Mile Marker</b>	7		
<b>Capacity</b>	16	<b>District</b>	1
<b>Truck Counts</b>			
<b>Date</b>	<b>Time</b>	<b>Count</b>	<b>% Utilization</b>
May 18, 2011	11:45 PM	7	44
May 19, 2011	8:00 AM	4	25
May 20, 2011	12:30 AM	6	38

### Notes

- This rest area is located at the south end of the Skyway bridge. Its truck parking capacity is on the low side with 16 truck parking spaces available. As is also the case with the Pinellas County rest area (north end of the Skyway bridge), this rest area mainly serves passenger cars and experiences low truck traffic.
- The security officer indicated that she saw the truck parking lot crowded only on national holidays.

## CHARLOTTE COUNTY REST AREA

### Truck Counts

<b>Interstate Number</b>	I-75		
<b>Facility Number</b>	10270		
<b>Mile Marker</b>	161		
<b>Capacity</b>	26	<b>District</b>	1
<b>Truck Counts</b>			
<b>Date</b>	<b>Time</b>	<b>Count</b>	<b>% Utilization</b>
May 1, 2011	11:36 PM	5	19
May 3, 2011	1:30 AM	16	62
May 4, 2011	1:45 AM	13	50

### Notes

- This rest area has a variety of nearby alternatives for truck drivers to use, including a gas station with a large parking lot, the parking lot of a big retailer, and a weigh plaza three miles south of the rest area. Given the extra capacity added by these alternatives, this rest area does not experience a significant parking capacity problem.
- An important point indicated by the security officers and FDOT personnel interviewed was the hesitation of truck drivers to use the weigh plaza which is only three miles south of the rest area. While a common issue in Florida, this problem requires attention if the capacity demands at rest areas are to be managed effectively.

## LEE COUNTY REST AREA

### Truck Counts

<b>Interstate Number</b>	I-75		
<b>Facility Number</b>	10280		
<b>Mile Marker</b>	131		
<b>Capacity</b>	50	<b>District</b>	1
<b>Truck Counts</b>			
<b>Date</b>	<b>Time</b>	<b>Count</b>	<b>% Utilization</b>
May 1, 2011	10:10 PM	13	26
May 3, 2011	12:50 AM	15	30
May 4, 2011	1:00 AM	12	24

### Notes

- This rest area's truck parking capacity is on the high side with 50 truck parking spaces available. As indicated by the security officer and truck drivers interviewed, this rest area does not experience a severe truck parking capacity problem, although it occasionally fills up depending on the produce season.
- A truck driver who uses this rest area twice every week regularly for overnight stay said that he typically finds the truck parking lot full only two (2) out of eight (8) times every month.



## COLLIER COUNTY REST AREA

### Truck Counts

<b>Interstate Number</b>	I-75		
<b>Facility Number</b>	10290		
<b>Mile Marker</b>	63		
<b>Capacity</b>	16	<b>District</b>	1
<b>Truck Counts</b>			
<b>Date</b>	<b>Time</b>	<b>Count</b>	<b>% Utilization</b>
May 2, 2011	1:50 AM	18	113
May 3, 2011	3:00 AM	17	106
May 4, 2011	2:45 AM	14	88

### Notes

- This rest area has one of the smallest truck parking lots in Florida with 16 spaces available. It is also in a remote location on the Alligator Alley portion of I-75 with no other nearby alternatives for truck drivers. Hence, this rest area experiences a high-level of truck parking demand and operates over its capacity during weeknights, especially between 2:00 AM and 5:00 AM.
- According to the FDOT Fort Myers Operational Office, this rest area is scheduled for reconstruction in fall 2012, and another facility will also be constructed on the opposite side at the same mile marker.

## **BROWARD COUNTY REST AREA**

### **Truck Counts**

<b>Interstate Number</b>	I-75		
<b>Facility Number</b>	40490		
<b>Mile Marker</b>	34		
<b>Capacity</b>	60	<b>District</b>	4
<b>Truck Counts</b>			
<b>Date</b>	<b>Time</b>	<b>Count</b>	<b>% Utilization</b>
May 2, 2011	2:30 AM	24	40
May 3, 2011	3:40 AM	20	33
May 4, 2011	3:25 AM	18	30

### **Notes**

- This rest area was built as a model rest area and has a truck parking capacity of 60 trucks, one of the highest observed by the research team in Florida.
- The security officer, who has been working at this rest area for the last eight years, indicated that he seldom saw the facility operate at its capacity. This statement was also confirmed by a truck driver whom the research team interviewed.

### 3.9 I-75 Corridor Truck Parking Problem Map

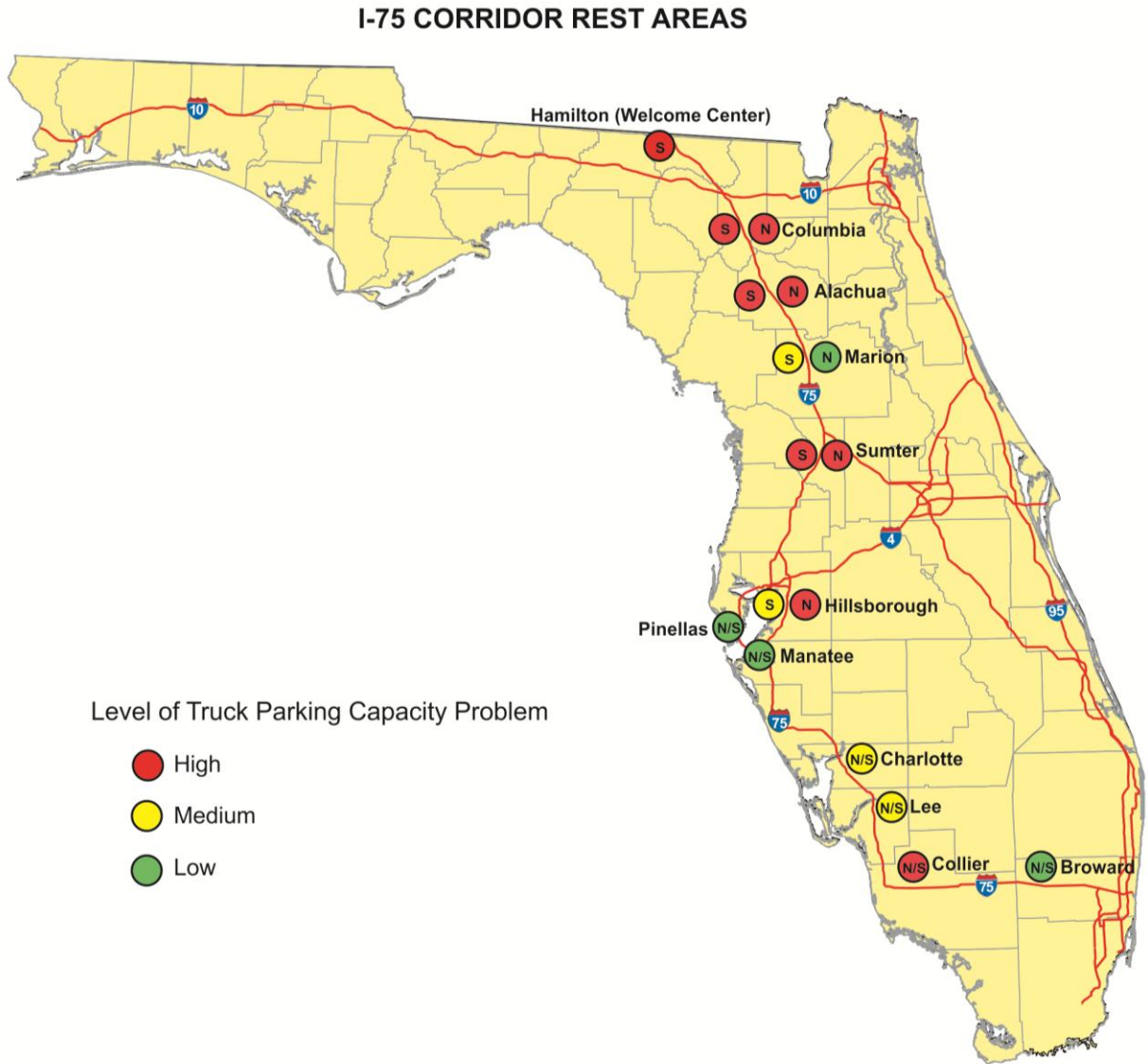

Figure 16: I-75 corridor truck parking problem map

### 3.10 Photographs Taken at I-75 Corridor Rest Areas



Figure 17: Research team members interviewing a truck driver at the Lee County rest area



Figure 18: Trucks parked on the shoulder at Columbia South



**Figure 19: Truck parked on the shoulder at Columbia North**



**Figure 20: Another truck parked on the shoulder at Columbia North**



**Figure 21: The truck parking lot of Alachua North during daytime**

### 3.11 I-95 Corridor Rest Area Reports

#### NASSAU COUNTY WELCOME CENTER

##### Truck Counts

<b>Interstate Number</b>	I-95		
<b>Facility Number</b>	20310		
<b>Mile Marker</b>	378		
<b>Capacity</b>	36	<b>District</b>	2
<b>Truck Counts</b>			
<b>Date</b>	<b>Time</b>	<b>Count</b>	<b>% Utilization</b>
June 16, 2011	1:15 AM	36	100
June 17, 2011	1:05 AM	29	81

##### Notes

- The security officer indicated that the truck parking lot reaches capacity almost every weeknight. He also indicated that many truck drivers related that they did not know about the availability of truck parking at the Welcome Center.
- The facility usually gets very busy at nighttime, but the research team did not observe any illegal parking outside of the truck parking lot. If the lot is full, the trucks simply leave. The access ramps do not have enough room for shoulder parking.



## ST. JOHNS COUNTY REST AREA (Mile Marker 331)

### Truck Counts

<b>Interstate Number</b>	I-95		
<b>Facility Number</b>	20611 Northbound		
<b>Mile Marker</b>	331		
<b>Capacity</b>	73	<b>District</b>	2
<b>Truck Counts</b>			
<b>Date</b>	<b>Time</b>	<b>Count</b>	<b>% Utilization</b>
June 16, 2011	4:00 AM	45	62
June 17, 2011	2:00 AM	33	45

<b>Interstate Number</b>	I-95		
<b>Facility Number</b>	20612 Southbound		
<b>Mile Marker</b>	331		
<b>Capacity</b>	67	<b>District</b>	2
<b>Truck Counts</b>			
<b>Date</b>	<b>Time</b>	<b>Count</b>	<b>% Utilization</b>
June 16, 2011	2:45 AM	50	75
June 17, 2011	2:15 AM	51	76

### Notes

- There are two rest areas in St. Johns County, one at mile marker 331 and the other at mile marker 302. The northbound and southbound facilities at mile marker 331 have a truck capacity of 73 and 67, respectively, which is one of the highest observed by the research team in Florida.
- The gas station with a large truck parking lot located south of the rest area reduces the demand for the northbound facility, whereas the southbound facility is the first option for truck drivers before the gas station; hence, the southbound facility typically gets more truck traffic than the northbound facility.
- According to the security officers, illegal parking happens rarely at the northbound facility, whereas illegal parking is occasionally observed at the southbound facility.



**ST. JOHNS COUNTY REST AREA (Mile Marker 302)**

**Truck Counts**

<b>Interstate Number</b>	I-95		
<b>Facility Number</b>	20331 Northbound		
<b>Mile Marker</b>	302		
<b>Capacity</b>	15	<b>District</b>	2
<b>Truck Counts</b>			
<b>Date</b>	<b>Time</b>	<b>Count</b>	<b>% Utilization</b>
June 16, 2011	4:30 AM	32	213
June 17, 2011	3:15 AM	29	193

<b>Interstate Number</b>	I-95		
<b>Facility Number</b>	20332 Southbound		
<b>Mile Marker</b>	303		
<b>Capacity</b>	18	<b>District</b>	2
<b>Truck Counts</b>			
<b>Date</b>	<b>Time</b>	<b>Count</b>	<b>% Utilization</b>
June 16, 2011	3:30 AM	32	178
June 17, 2011	3:00 AM	30	167

**Notes**

- The northbound and southbound facilities at this rest area are much smaller than that of the other St. Johns County rest area at mile marker 331. They both have a small RV lot which is used for overflow parking.
- Both facilities operate over capacity almost every weeknight. The research team observed illegal parking at both facilities after midnight.

## BREVARD COUNTY REST AREA (Mile Marker 227)

### Truck Counts

<b>Interstate Number</b>	I-95		
<b>Facility Number</b>	50341 Northbound		
<b>Mile Marker</b>	225		
<b>Capacity</b>	26	<b>District</b>	5
<b>Truck Counts</b>			
<b>Date</b>	<b>Time</b>	<b>Count</b>	<b>% Utilization</b>
May 12, 2011	3:00 AM	46	177
May 12, 2011	5:00 AM	41	158
May 13, 2011	3:15 AM	29	193
May 14, 2011	1:30 AM	30	115

<b>Interstate Number</b>	I-95		
<b>Facility Number</b>	50342 Southbound		
<b>Mile Marker</b>	227		
<b>Capacity</b>	22	<b>District</b>	5
<b>Truck Counts</b>			
<b>Date</b>	<b>Time</b>	<b>Count</b>	<b>% Utilization</b>
May 12, 2011	12:00 AM	50	227
May 12, 2011	4:00 AM	56	255
May 13, 2011	12:00 AM	47	214
May 13, 2011	6:00 AM	46	209

### Notes

- There are two rest areas in Brevard County, one at mile marker 227 and the other at mile marker 169. The northbound facility of this particular rest area is typically busy, whereas the southbound facility is extremely busy. Both facilities have a picnic area used for truck parking, adding an additional capacity of 10 to 15 trucks.
- Both facilities in this rest area have a severe capacity problem regarding nighttime truck parking. The research team has observed illegal parking on access ramps and highway shoulders at both facilities.

## BREVARD COUNTY REST AREA (Mile Marker 169)

### Truck Counts

<b>Interstate Number</b>	I-95		
<b>Facility Number</b>	50381 Northbound		
<b>Mile Marker</b>	168		
<b>Capacity</b>	70	<b>District</b>	5
<b>Truck Counts</b>			
<b>Date</b>	<b>Time</b>	<b>Count</b>	<b>% Utilization</b>
May 12, 2011	2:30 AM	37	53
May 13, 2011	4:00 AM	41	59
May 14, 2011	12:00 AM	26	37

<b>Interstate Number</b>	I-95		
<b>Facility Number</b>	50382 Southbound		
<b>Mile Marker</b>	169		
<b>Capacity</b>	70	<b>District</b>	5
<b>Truck Counts</b>			
<b>Date</b>	<b>Time</b>	<b>Count</b>	<b>% Utilization</b>
May 12, 2011	3:00 AM	71	101
May 13, 2011	2:00 AM	56	80
May 13, 2011	6:00 AM	58	83

### Notes

- The northbound and southbound facilities at this rest area have a truck parking capacity of 70 each, one of the highest observed by the research team in Florida. According to a security officer, the northbound facility can typically accommodate the demand for truck parking very well and rarely reaches capacity. On the other hand, the southbound facility is usually much more crowded and either reaches or approaches capacity almost every weeknight.
- The research team did not observe any illegal parking outside of the rest area; all overflow trucks were parked within the commercial vehicle parking lot.

## ST. LUCIE COUNTY REST AREA

### Truck Counts

<b>Interstate Number</b>	I-95		
<b>Facility Number</b>	40391 Northbound		
<b>Mile Marker</b>	133		
<b>Capacity</b>	48	<b>District</b>	4
<b>Truck Counts</b>			
<b>Date</b>	<b>Time</b>	<b>Count</b>	<b>% Utilization</b>
May 12, 2011	6:00 AM	25	52
May 13, 2011	4:00 AM	27	56
May 14, 2011	12:00 AM	20	42

<b>Interstate Number</b>	I-95		
<b>Facility Number</b>	40392 Southbound		
<b>Mile Marker</b>	133		
<b>Capacity</b>	48	<b>District</b>	4
<b>Truck Counts</b>			
<b>Date</b>	<b>Time</b>	<b>Count</b>	<b>% Utilization</b>
May 12, 2011	5:00 AM	44	92
May 13, 2011	2:00 AM	48	100
May 13, 2011	6:00 AM	24	50

### Notes

- The security officers indicated that the southbound facility is full almost every weeknight as trucks are moving towards to Miami. The northbound facility occasionally reaches capacity.
- The research team did not observe any illegal parking outside of the rest area. It was observed that various undesignated spaces within the commercial vehicle parking lot were being used by overflow trucks.

## MARTIN COUNTY REST AREA

### Truck Counts

<b>Interstate Number</b>	I-95		
<b>Facility Number</b>	40401 Northbound		
<b>Mile Marker</b>	106		
<b>Capacity</b>	55	<b>District</b>	4
<b>Truck Counts</b>			
<b>Date</b>	<b>Time</b>	<b>Count</b>	<b>% Utilization</b>
May 12, 2011	3:00 AM	43	78
May 13, 2011	1:00 AM	37	67
May 13, 2011	11:00 PM	20	42

<b>Interstate Number</b>	I-95		
<b>Facility Number</b>	40392 Southbound		
<b>Mile Marker</b>	133		
<b>Capacity</b>	55	<b>District</b>	4
<b>Truck Counts</b>			
<b>Date</b>	<b>Time</b>	<b>Count</b>	<b>% Utilization</b>
May 12, 2011	12:00 AM	67	122
May 13, 2011	3:00 AM	55	100
May 13, 2011	6:00 AM	35	64

### Notes

- The parking trends observed in this rest area were very similar to those observed in St. Lucie County. The security officers indicated that the southbound facility is usually more crowded than the northbound facility because it is the last stop for truck drivers on I-95 before Miami. The southbound facility operates over capacity almost every weeknight during nighttime, whereas the northbound facility reaches capacity one to two (1-2) nights a week on average.
- The research team did not observe any illegal parking outside of the rest area. It was observed that various undesignated spaces within the commercial vehicle parking lot were being used by overflow trucks.

### 3.12 I-95 Corridor Truck Parking Problem Map

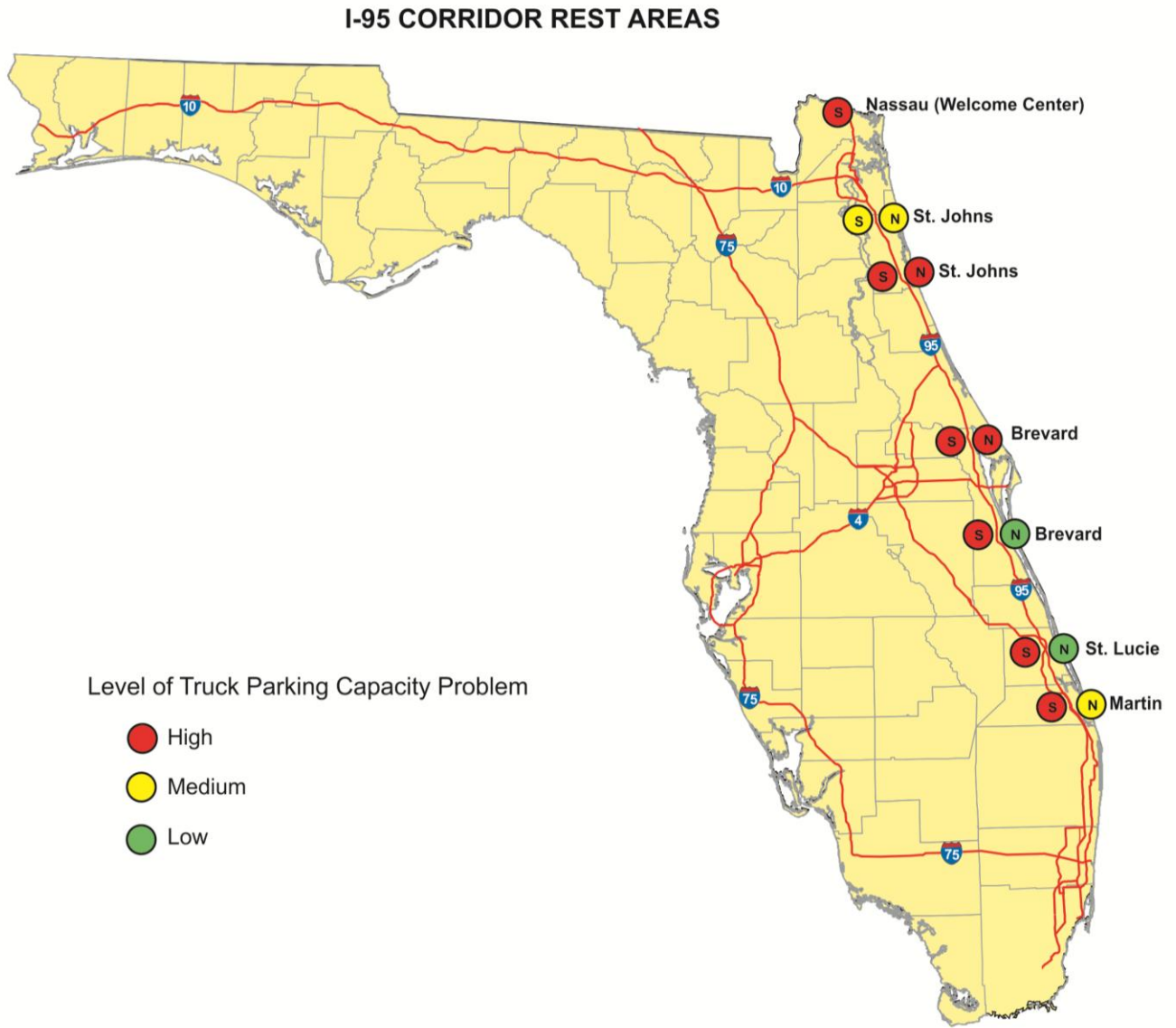

Figure 22: I-95 corridor truck parking problem map

### 3.13 Photographs Taken at I-95 Corridor Rest Areas



**Figure 23: Trucks parked on the highway shoulder at Brevard North (MM 227)**



**Figure 24: Trucks parked on the exit ramp and highway shoulder at Brevard North (MM 227)**



**Figure 25: Trucks parked on the exit ramp at Brevard North (MM 227)**



**Figure 26: A truck parked on the highway shoulder at Brevard North (MM 227) getting ready to leave just after sunrise**





**Figure 27: Truck parked on the exit ramp at Brevard South (MM 227) in the early hours of the day**



**Figure 28: Ruined pavement due to shoulder parking at St. Johns**



**Figure 29: Trucks parked on the highway shoulder at St Johns (MM 302)**

## **4. PHASE-2: IMPLEMENTING A SMART PARKING MANAGEMENT SYSTEM FOR COMMERCIAL TRUCKS**

### **4.1 Introduction**

Phase-2 of this research project included an assessment of technology that can be used to improve truck parking management at rest areas in Florida and deploy a pilot project to test implementation. The overriding thesis for this research was that providing better information to truck drivers about parking availability can reduce the number of trucks parking on shoulders, crashes due to driver fatigue, and unnecessary diesel emissions. The smart parking management system for commercial motor vehicles presented in this report is based on the following tenets (Smith et al., 2005):

1. The system must accurately and reliably “know” whether a parking area is full, and if it is not full, the number of spaces remaining (Smith et al., 2005).
2. The system must include the capability to archive data, so that historical information on parking occupancy can be assembled and monitored (Smith et al., 2005).
3. The system must forecast space availability for approaching drivers at a micro-level by combining the real-time parking space occupancy information with the historical parking trend information. Smith et al. (2005) indicates: “Even a perfectly accurate parking occupancy detection system will only indicate the number of spaces available at a particular point in time. What the driver needs, however, is an indication of whether spaces will be available at the time he or she arrives at the rest area.” Moreover, in cases where information is being broadcast over a wide area (for example, to drivers who are still many miles away), it is not enough to simply provide the current space availability, when that information is likely to change by the time the driver arrives (Smith et al., 2005).

## 4.2 Wireless Vehicle Detection System

In order to make the best decision in choosing the appropriate technology for the proposed smart parking management system, the research team has completed the following steps: (i) a detailed literature review as summarized in Chapter-2, (ii) meetings with the FDOT personnel and other stakeholders to gather their technical, functional, and non-functional requirements from the proposed system, and (iii) a review of commercially available technologies which could be used for the purpose of this research. Ultimately, the decision as to what technology and approach were most appropriate was made after weighing factors such as available technology and their suitability for truck parking applications, discussions with potential vendors, survey of the chosen pilot project rest area and its infrastructure, and schedule and budget considerations.

The vehicle detection technology chosen for the pilot project and presented in this report features wireless ground sensors, which detect the presence of a vehicle as it comes to a stop above them. The system was provided and installed at the selected site by IPsens, LLC, which was contracted to act as the integrator and general contractor on the project. Nedap AVI of the Netherlands is the manufacturer of all the required hardware (Figure 30).



**Figure 30: Wireless vehicle detection system application at a rest area in Europe**  
(Source: [www.nedapavi.com](http://www.nedapavi.com))

## **System Components and Hardware Description**

The actual occupancy determination is accomplished using a unique combination of differential magnetic induction measurement with a built-in infrared sensor. This combination technology allows the sensors to accurately determine the presence of a high-clearance truck chassis without confusing it with another vehicle parked in an adjacent space. The sensors communicate through a network of wireless mesh repeaters, which relay information to data collectors on the premises. The data collectors in turn are connected to a central database via the Internet. Informational maps, historical reports, and a number of other applications can be accessed by the user, along with other shared data platforms and devices such as smart phones (Figure 31).

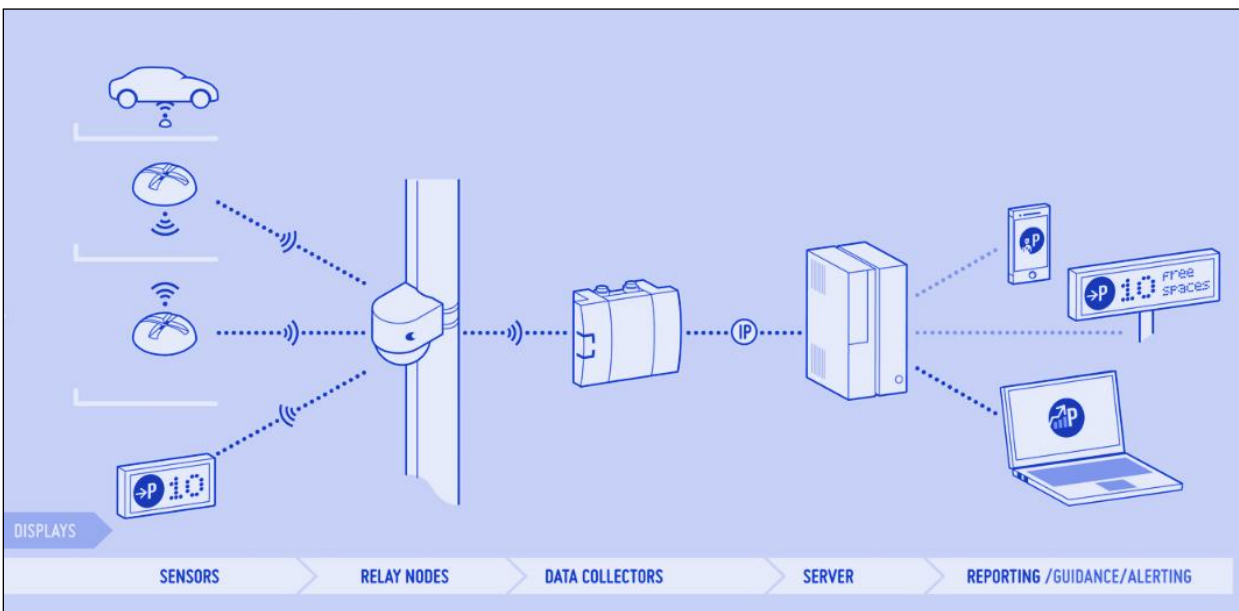
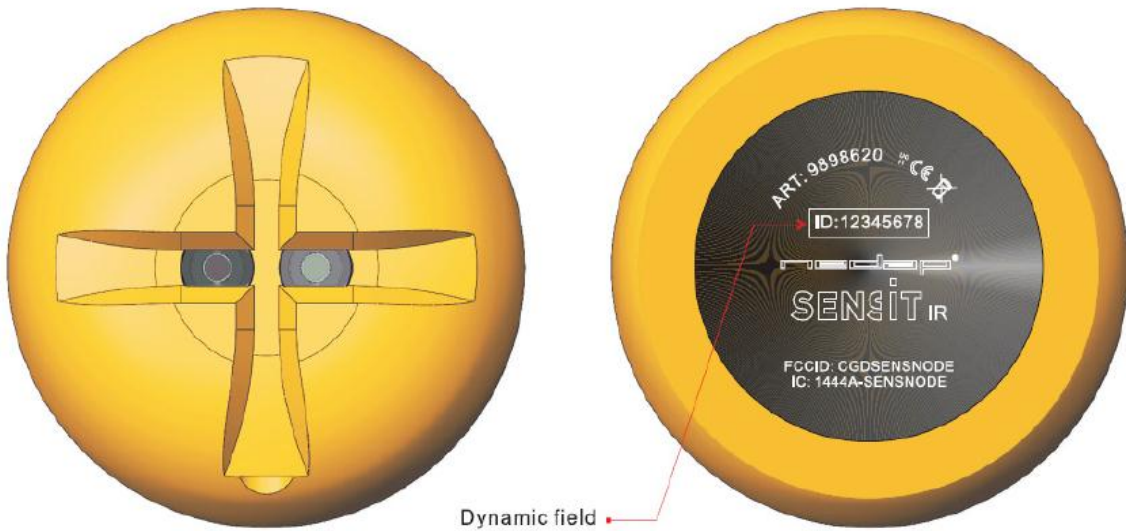

**Figure 31: System components and hardware description**

The wireless vehicle detection system presented in this report is comprised of several subcomponents performing specific roles in capturing and transferring data to the back-end. Below is a description of the system hardware components. Technical specifications for these components can be found in Appendix-A.

### Sensor Nodes

Detection nodes are ground sensors that can detect vehicle presence via magnetic and infrared sensors (Figure 32 and 33). This information is then communicated wirelessly to relay nodes, which in turn relay the information to a data collector.



**Figure 32: Top view (left) and bottom view of the ground sensor**

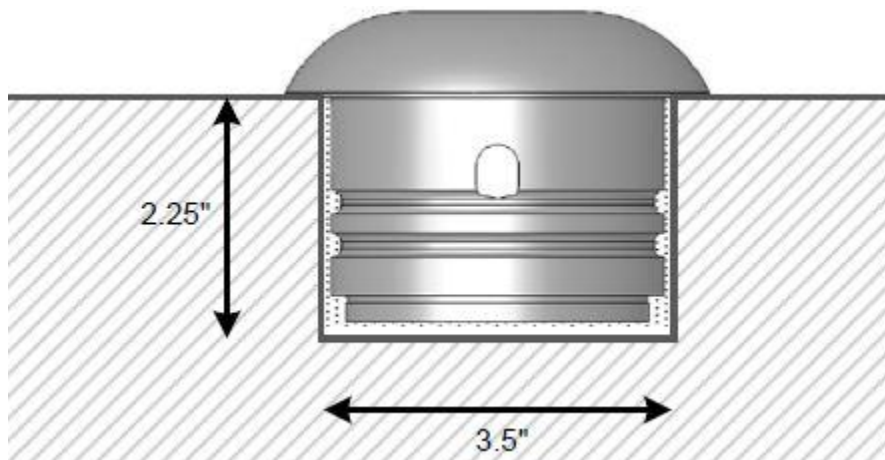

**Figure 33: Ground level section view of the sensor**

### ***Relay Nodes***

Relay nodes are used to pass information from the ground sensors back to the data collector. These nodes are typically mounted 10 feet or higher off the ground and require a semi-line of sight between other system components. Relay nodes ensure faster communication between the sensors and data collector, as well as an alternate or redundant means of communication for delivering information to a data collector.

### ***Data Collectors***

Data collectors are communication hubs that receive information being passed along from relay and detection nodes, and then make that raw information available via serial or Ethernet connections. In doing this, the collector provides an interface between the detection nodes and the host system, whether local or cloud-based.

## **4.3 Site Selection and Site Survey**

After deciding on the vehicle detection technology to be used in this research, the next task included selection of the site for the pilot project. Related activities included: (1) define preliminary site-selection criteria; (2) identify candidate parking facility locations in Florida that meet the criteria; (3) gather and assess general information on parking conditions for candidate locations; (4) conduct physical surveys at the most promising parking areas; and (5) select the optimal location for system deployment.

Two preliminary site-selection criteria were defined by the research team: (i) level of truck parking capacity problem and (ii) location. Based on these two criteria and using the information collected in the first phase of the project, the research team identified three candidate rest areas that presented a high-level truck parking capacity problem and illegal parking activity, as well as an easy access point (i.e., location) for travel and procurement purposes. Site surveys and analyses at the shortlisted rest areas were conducted in conjunction with the baseline information gathered in the first phase of the research and included the collection of additional information, such as inventory of current structures, trees, light poles and electrical sources on the site, availability of power and communications, lot size and configuration, and need for work permits for



system installation. Ultimately, the Leon County rest areas (eastbound and westbound) on I-10, located two miles west of Tallahassee, were selected by FDOT as the pilot project site for the wireless vehicle detection system described above (Table 2, Figure 34, 35, and 36).

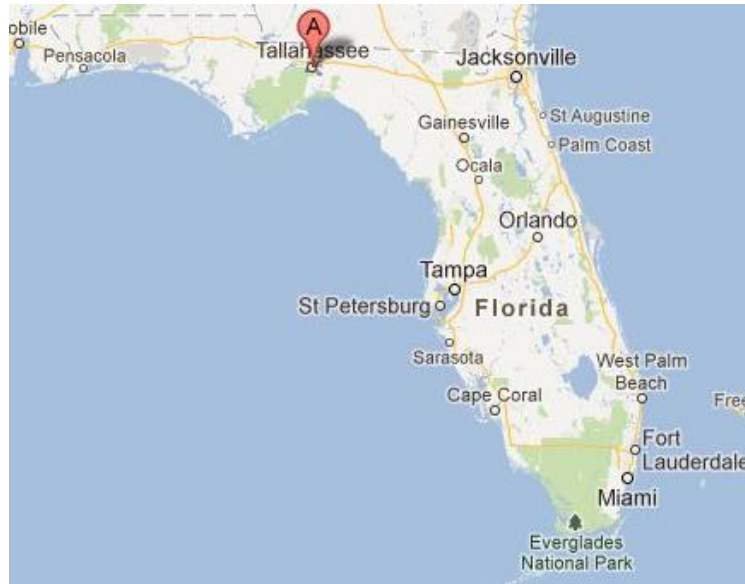

**Figure 34: Leon County rest area outside of Tallahassee, FL**

**Table 2: Leon County rest area information**

<b>Facility Number</b>	30081 Eastbound 30082 Westbound
<b>Interstate Number</b>	I-10
<b>Prior Exit Number</b>	192 Eastbound 196 Westbound
<b>Mile Marker</b>	194
<b>Facility Type</b> FF = Handicapped facilities, restrooms, picnic tables, drinking water, pet exercise areas, outside night lights and telephones. V = Vending machines	FF, V 40 Picnic Shelters: (24 East, 16 West) 56 Picnic Tables: (24 East, 32 West) No Walking Trails
<b>Nighttime Security</b>	Yes





**Figure 35: Leon County rest area (Eastbound)**



**Figure 36: Leon County rest area (Westbound)**

#### 4.4 System Design and Layout

To develop the appropriate system design and layout for the Leon County rest areas (eastbound and westbound), the basic functions of each component within the proposed wireless vehicle detection system were reviewed, taking into account the findings of the site survey and the technical specifications of the system components. Optimal communication for the wireless vehicle detection system relies on proper placement of the system components on-site. The primary guideline is to ensure components have a general line of sight between one another and do not exceed the documented distance limitations for communication.

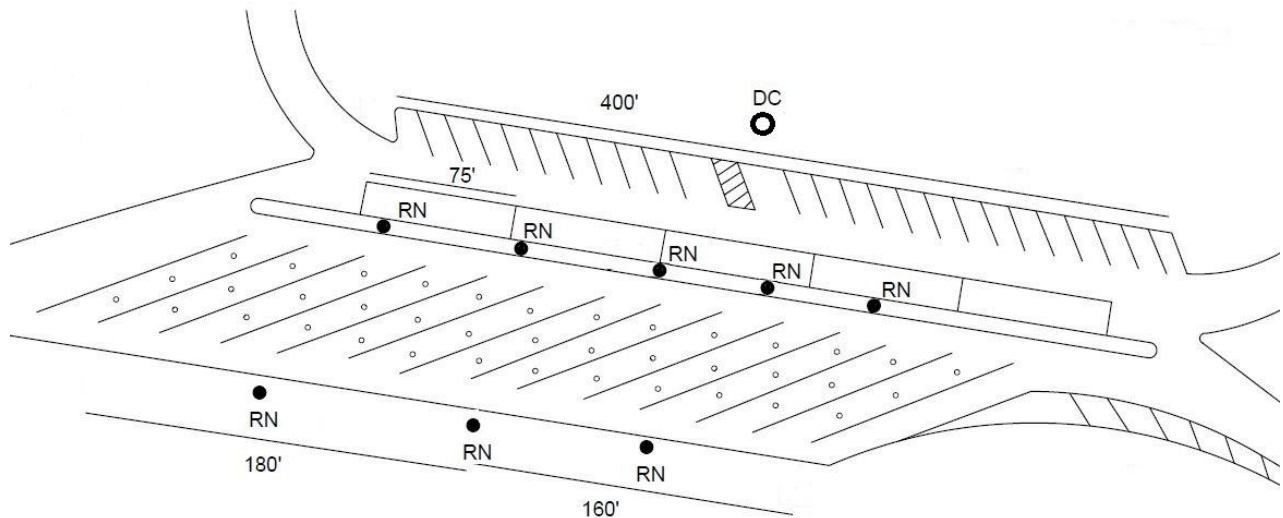

**Figure 37: Leon County rest area system design and layout**

The final system design and layout for the Leon County rest areas is shown in Figure-37. The eastbound and westbound rest areas mirror each other with equipment installation. Both rest areas contained 13 truck parking spaces each. Each parking space was elected to have three equally spaced sensors to maximize sensing accuracy, which led to installation of 78 ground sensor nodes in each rest area. Also, a total of eight (8) relay nodes were installed in each rest area, including three (3) nodes attached to existing light

poles and three (5) nodes attached to small sign poles installed by the contractor. These additional poles were necessary to provide optimum network coverage. Finally, a data collector was placed 20 feet above ground level in each rest area to complete the network. In the wireless vehicle detection system, only data collectors require main power, whereas the sensor nodes and the relay nodes are battery powered.

#### **4.5 Hardware Installation**

Preparation for the hardware installation included a review of the scope of work, along with the tools and labor necessary for project implementation. Sensors were to be placed on the asphalt road surface, with relay nodes being installed overhead on light poles. This required the use of both a core drill for the road surface and a bucket truck for the placement of the overhead equipment. The complete list of equipment required for installation is as follows:

- Core Drill (Water Cooled)
- Core Drill Bit (3½ -inch inner diameter)
- Water Tank or Source for drill
- Wet/Dry Vacuum
- Powered Hand Chipper
- Chisel or Flathead Screwdriver
- Quick-setting Mortar
- Mix tank or Buckets for Mortar
- Mortar Trowel
- Electrical Outlet or Generator
- Chalk or Construction Spray Paint
- Nylon String
- Detector Node Initiator Magnet
- Bucket Truck

#### **Sensor Installation**

The initial step in preparing for installation of the sensors included distribution of on-site safety signage and the coning off of work areas. Alternate traffic routes were also designated. Installation areas required the absence of vehicles for about eight (8) hours to allow for proper mortar cure times.

After marking off the work zone, the process of confirming measurements and sensor placement based on the original installation plan was started. Locations for the drilling of the first sensors were marked using chalk. The absolute middle of the parking space was

marked for node placement, followed by two additional marks for nodes in the same parking space. These markings were placed in the center of the same parking space at 25-foot intervals on either side of the original center mark. The sensors were to be installed in straight lines across the parking spaces, so a nylon string was used to maintain the accuracy of the line during the initial markings. Starting with the initial markings for sensor placement in the first parking space, subsequent markings were made in the following parking spaces with the aid of the nylon guide line.

Once all the parking bays were marked, the core drilling process was initiated. A 3½-inch inner diameter core bit was used to drill for sensor placement (Figure 38). The holes were drilled to a depth of 2¼ inches (Figure 39). This allowed the mortar a small amount of room to settle beneath the sensors themselves. After the drilling of a hole was completed, the core was removed. Sometimes the use of a chisel or flathead screwdriver and hammer was needed to loosen the core from its base. Any excess road base within the hole was chipped away, and the remaining water and debris from the bottom of the hole was vacuumed (Figure 40).



**Figure 38: Core drilling process**





**Figure 39: The core before removal**



**Figure 40: The removed core and the sensor to be installed**

After all the required holes were ready, a sensor was placed next to each hole in no particular order. The sensor ID was then read from the top of each sensor and recorded on the installation map. This was important because the sensor ID could become illegible due to wear and tear, and knowing the exact location of each unique sensor is important for data collection and troubleshooting in the future.

The quick drying mortar required for sensor node installation was prepared once drilling was over, in accordance with the manufacturer's specifications. The optimal consistency of the mortar was found to be that of toothpaste. Previous experience of the contractor indicated that excessive amounts of water in the mortar led to the sensor floating within the hole and protruding.

Application of the mortar and placement of the sensors was performed one parking space at a time from the east to west sides of the rest area. Approximately eight (8) ounces of mortar was placed in each hole. The contractor made sure that enough mortar was used so that when the sensor was pressed into the hole, a small amount of mortar came out of the top. The excess mortar was removed from around the edge of the sensor and the tops of each sensor were cleaned with a wet cloth (Figure 41).



**Figure 41: Sensor being installed by the technician**

Sensors are shipped to site from the factory in “sleep mode.” A sensor reverts to sleep mode if it does not see a network for a long period of time. This design preserves the battery of the sensor in the event of accidental initiation. Therefore, once a sensor was installed, the activation magnet was waved over the sensor to initiate the sensor’s active mode, i.e., sensor “wake up.” This process placed the sensors in a more active state, reporting their status more frequently. If no network is in place yet, the sensors will gradually slow down their frequency of communication again over the course of a 24-hour period. This step can be performed at a later time, if the data collector and back-end network are not available yet; however, regardless of when performed, it is easier to implement when no vehicles are over the sensors.



**Figure 42: The first row of sensors after installation**

### **Relay Node Installation**

Relay nodes are mounted to light poles via stainless steel bands. Each pole mounted weighed less than three (3) pounds, including the relay nodes which weighed less than a pound each; hence, structural weight capacity was not a concern for the poles. Relay nodes were placed on several light poles within the rest area. These nodes were mounted approximately 20 feet above ground in order to communicate over the top of trucks to other relay nodes on-site (Figure 43).



**Figure 43: Relay node mounted to light pole**

Relay nodes have a maximum communication distance of 182 feet, so it was necessary to install additional poles for relay node placement on-site (Figure 44). These additional



poles, 10 feet in height, were placed in the existing median, which separated the truck parking area from other vehicle parking, and relay nodes were attached to the top of each pole. This provided the proper amount of coverage and overlap for the network to communicate effectively. The relay nodes are battery powered (similar to that of the sensors in the ground), thus no power access on the poles was needed. The relay nodes were also activated with the node magnet due to the same reasons previously discussed.



**Figure 44: Relay node mounted to traffic sign pole**

### **Data Collector and Camera Installation**

The data collector is the main network hub for the wireless vehicle detection system, collecting data passed to it from the relay nodes. It is the only system component that

requires main 110V power. Due to this requirement, the data collector was placed at a central pole close to the main building, with power running from the rest area breaker box to the pole and up to the data collector (Figure 45). The data collector functions as the bridge between the local sensor network and the Internet. Therefore, the data collector must be connected to an internet source in order to take advantage of its remote access features. The Leon County rest areas had no preexisting Internet connectivity available. To address this issue, cellular modems were placed inside the data collectors in order to make the system remotely accessible. In addition, wireless routers were installed, providing both web-based security and wireless access to the system directly from on-site.



**Figure 45: Data collector mounted to light pole**

Another important feature of the wireless vehicle detection system included the cameras that were placed beneath the data collectors at both rest areas (Figure 46). The cameras were used to test the accuracy of the system.



**Figure 46: Data collector and the camera**

## **5. GIS MAPPING APPLICATION AND REPORT GENERATION**

### **5.1 Introduction**

This chapter describes the software tools developed to complement the wireless vehicle detection system introduced in Chapter-4, including the GIS mapping application and the report generation module.

### **5.2 Network Administration and System Diagnostics**

Management of data received from the sensors at the rest area begins on a network of servers monitored and managed by IPsens. These servers collect all incoming data from the site via a secure VPN connection and propagate the SQL relational database used for the generation of reports later on.

The reliability of sensor data is of major importance. Network strength tests, sensor interrogation, data latency evaluation, and sensor calibration are all diagnostics provided by the vendor. Coupled with built-in sensor-level diagnostic intelligence, these services allow for increased system reliability and accuracy.

### **5.3 Online Access to Software Tools**

The GIS mapping application as well as the report generation module developed for the pilot project at the Leon County rest areas can be accessed over the Internet at: [http://ipspark.webhop.net/ipro\\_fldot\\_pilot](http://ipspark.webhop.net/ipro_fldot_pilot). Access to the online system is currently password protected; however, readers interested in reviewing these software tools can contact the Principle Investigator (PI) to receive login information. The following sections provide an overview of the GIS mapping application and the report generation module.



**Log In**

*Please enter your User Name and Password and then click Log In.*

User Name:

Password:

**Figure 47: Login screen**

Once logged on to the system, the user can access the GIS mapping application (Actions > GIS map) and the report generation module (Actions > Occupancy) using the “Actions” tab.

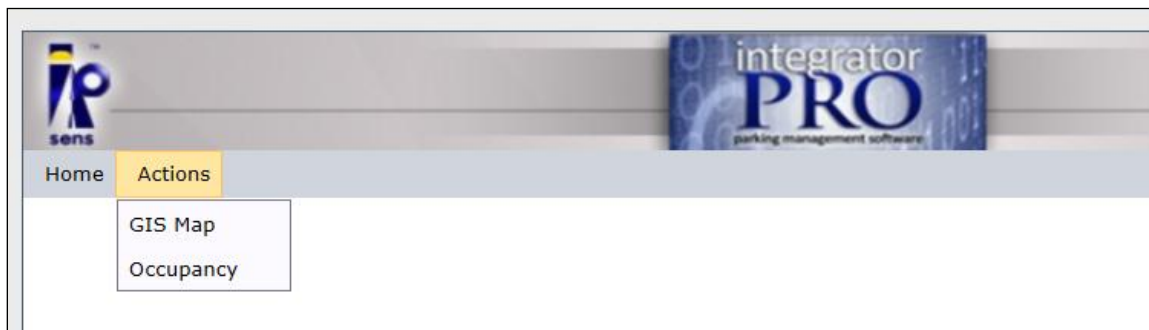

**Figure 48: Main menu**

## 5.4 GIS Mapping Application

The GIS mapping application developed for the pilot project at the Leon County rest areas represents an easy-to-read site map that offers a real-time feed of the sites' truck parking information (Figures 49, 50, 51, and 52).

The Web-based application allows for both an administrative and public interface. Administrative rights allow users total access to all information from the Leon County rest areas. Users at this level gain immediate access to an operator overview of the site, enabling both a broad view of the site or detailed information at the sensor level. Administrators can also make adjustments to the visual layout of the map, change preferences, and gain access to the video integration portion, which shows a live feed of on-site parking activity. This access level also controls the data available to view through the public interface of the map, adjusting the map to show more relevant data for general public usage.

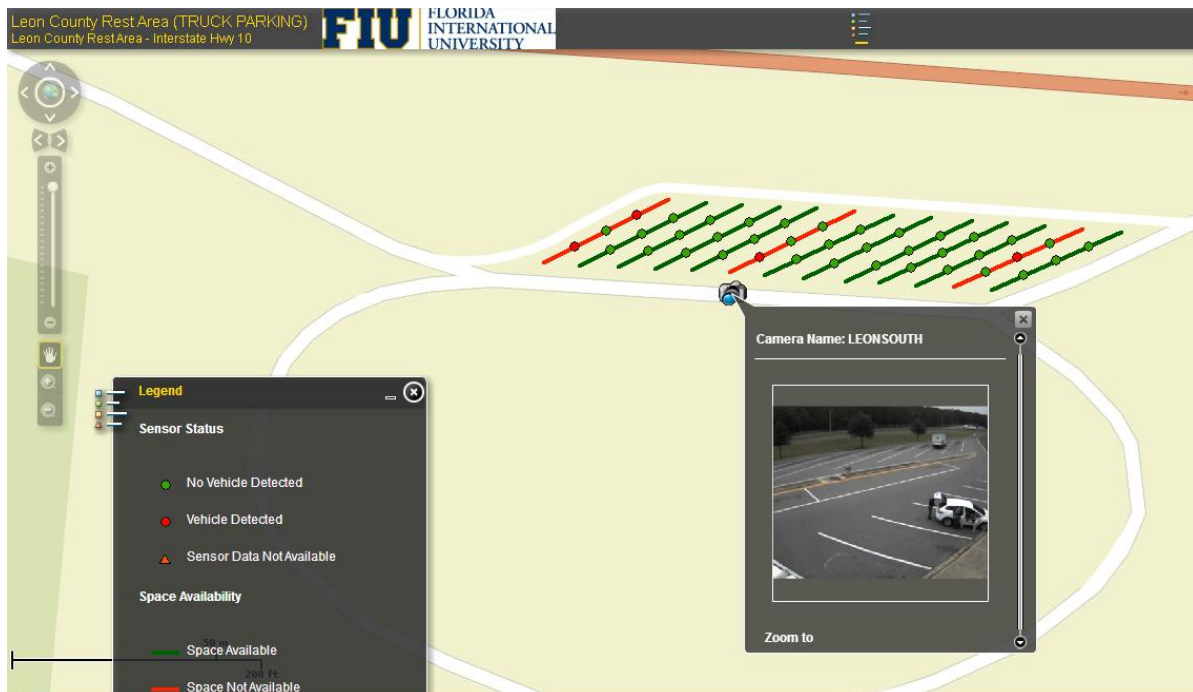
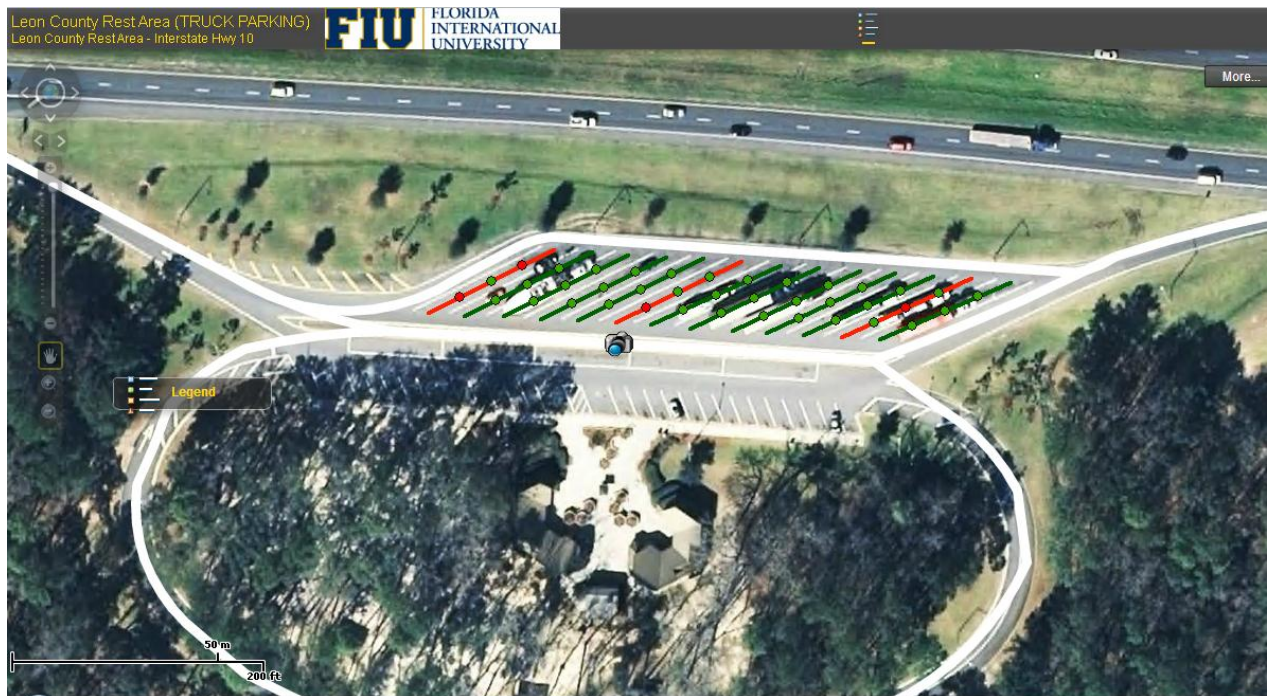

Figure 49: GIS interface





**Figure 50: Camera view (Leon East)**



**Figure 51: GIS interface in aerial view (Leon East)**

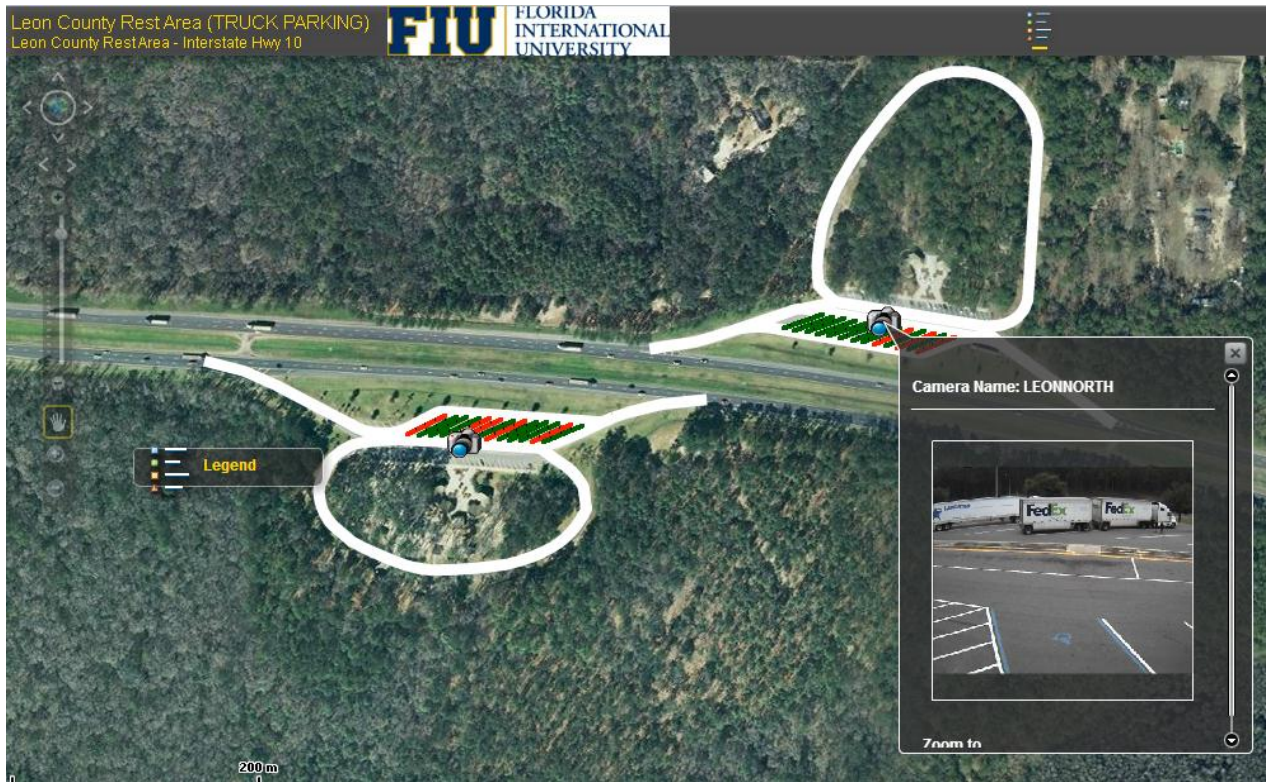
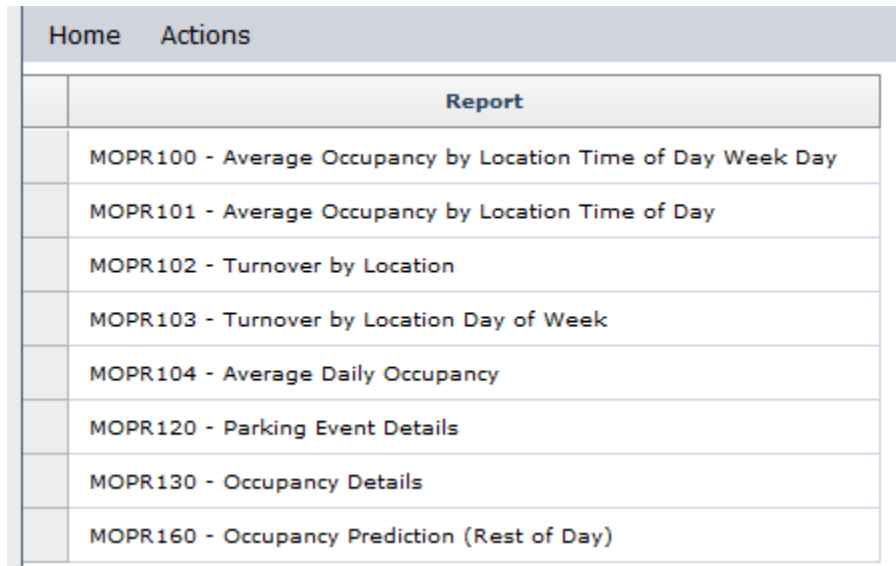

Figure 52: GIS interface in aerial view capturing both rest areas



## 5.5 Report Generation

The report generation module developed for the pilot project at the Leon County rest areas offers immediate access to historical truck parking data collected from these facilities (Figure 53).



Home	Actions
	<b>Report</b>
	MOPR100 - Average Occupancy by Location Time of Day Week Day
	MOPR101 - Average Occupancy by Location Time of Day
	MOPR102 - Turnover by Location
	MOPR103 - Turnover by Location Day of Week
	MOPR104 - Average Daily Occupancy
	MOPR120 - Parking Event Details
	MOPR130 - Occupancy Details
	MOPR160 - Occupancy Prediction (Rest of Day)

**Figure 53: Report generation module main menu**

The report types currently available in the report generation module include:

- **Average occupancy by location; time of day; week day:** This report provides average hourly truck counts for the selected rest area, date and time range, and the specified days of the week. The user can control all of the parameters above. For example, the user can create an occupancy report for a specific rest area, a specific date range, and specific days within that date range. This report is useful for viewing the parking trends specific to different weekdays in the selected period (Figures 54 and 55).
- **Average occupancy by location; time of day:** This report provides average hourly truck counts for the selected rest area and specified date range. For example, the user can create an occupancy report for a specific rest area and a

specific date range. Unlike the first report, this report generates average occupancy for the provided date range as a whole. This report is useful for viewing overall parking trends when the daily breakdown is not important.

**MOPR100 - Average Occupancy by Location Time of Day Week Day**

Choose Report Format:

**ObservationTms: 10/3/2012, Start of Day - 10/3/2012, End of Day**

**Presets:**

Current Day 
  Current Week 
  Current Month 
  Current Quarter 
  Current Year 
  User defined

**From:**   Use Current date

**To:**   Use Current date

**Time of Day**

Start of Day 
 End of Day 
 User Time

**TimeOfDay: 0 - 23**

**DaysOfWeek: 1 - 7**

**Rest Area: Leon Rest Area West Bound**

**Figure 54: User input screen to generate occupancy reports**

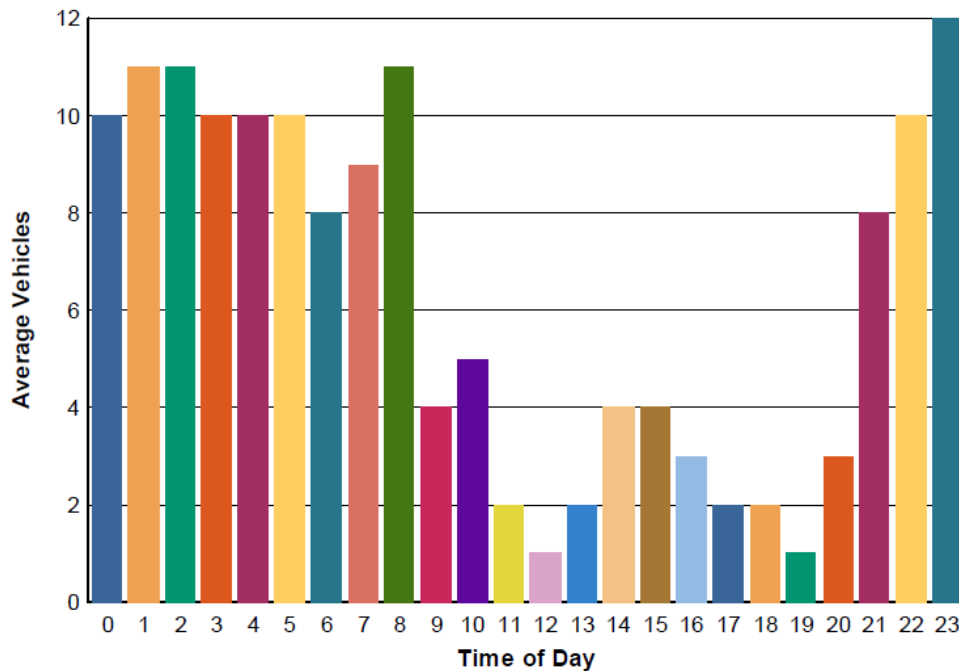

**Figure 55: Occupancy report Leon West for 10/03/2012 (example report)**

- **Turnover by location:** This report provides average number of trucks parked per day at the selected rest area for the specified date range. For example, the user can create a report for a specific rest area and a specific date range to generate the average number of trucks parked per day at that location. This report is useful for viewing the average number of trucks parked per day in the selected period; e.g., average number of trucks parked per day in the first week of October (Figure56).
- **Turnover by location; day of week:** This report provides average number of trucks parked per day at the selected rest area for the specified date range and by the specified day of week. For example, the user can create a report for a specific rest area and a specific date range that provides the average number of trucks parked per day for the specified weekdays. This report is useful for viewing the parking trends specific to different weekdays in the selected period; e.g., average number of trucks parked per day on Tuesdays in the month of October.

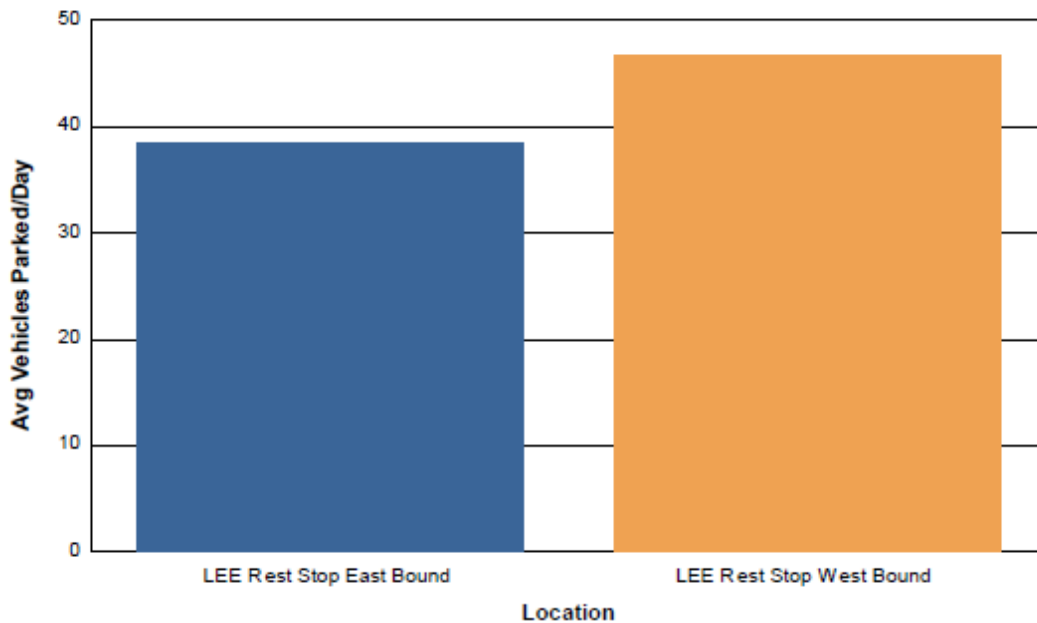

**Figure 56: Average number of trucks parked per day at the Leon County rest areas for the period of 09/15/2012 to 10/01/2012 (example report)**

- Average daily occupancy:** This report provides average daily occupancy at the selected rest area for the specified date range in terms of percent occupied and percent available spaces. This report is useful for viewing the average percent occupancy for the selected period (Figure 57).

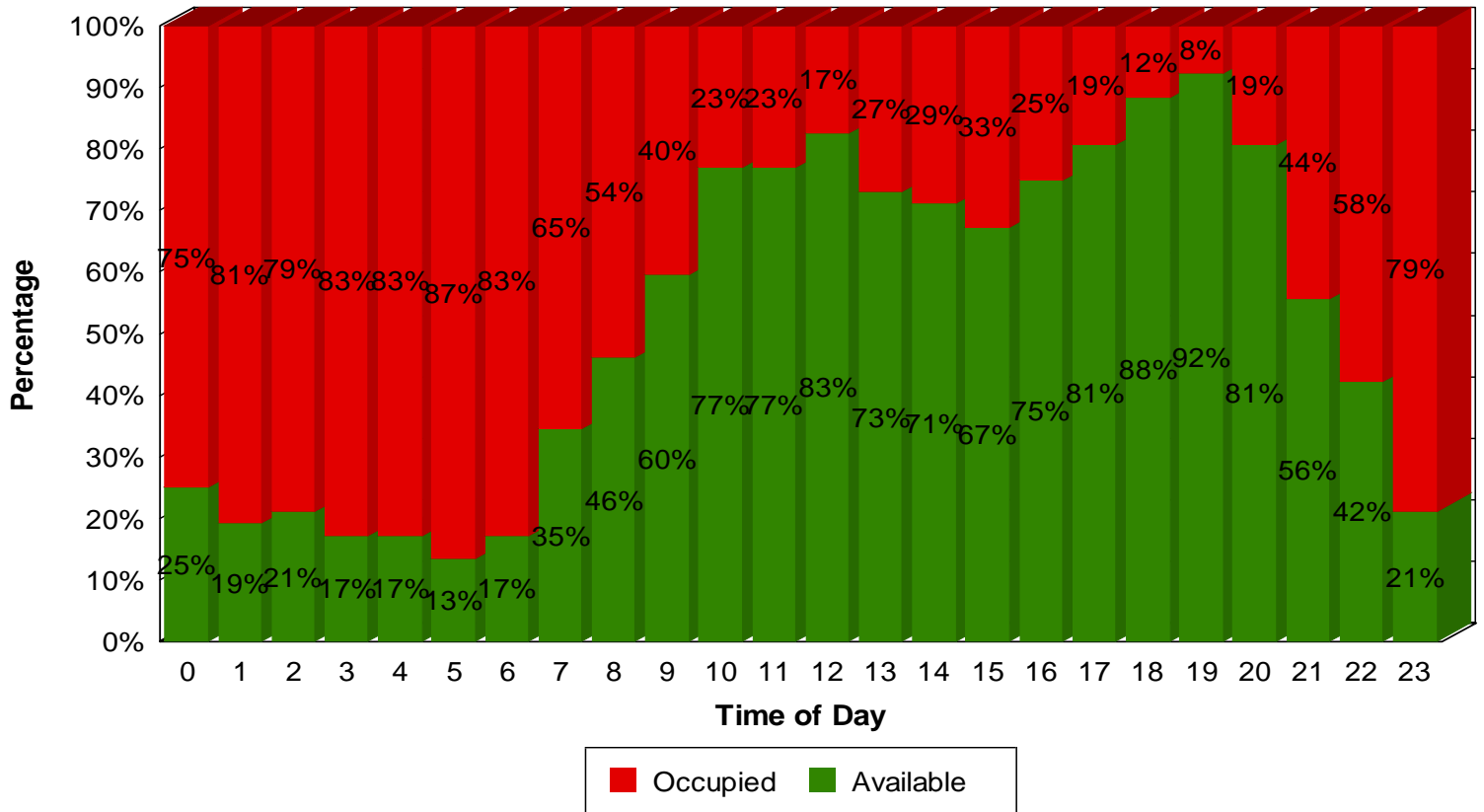

**Figure 57: Average percentage occupancy at the Leon West rest area for the period of 10/01/2012 to 10/4/2012 (example report)**

- Parking event details:** This report provides parking event data at the selected rest area for the specified date range with an optional event filter by time (duration of event). For example, the user can create a report for a specific rest area and a specific date range that provides the parking events which lasted more than a specified duration. This report is useful for retrieving the individual parking event data for the selected period (Figure 58).

Location: Leon Rest Area East Bound				
Space	Event Start Time	Event End Time	Elapsed Time	
LEES003	10/2/2012 8:09:41PM	10/3/2012 6:28:19AM	10Hr 19Min	
LEES013	10/2/2012 10:35:19PM	10/3/2012 5:27:23AM	6Hr 52Min	
LEES001	10/2/2012 11:02:01PM	10/3/2012 7:49:29AM	8Hr 47Min	
LEES011	10/2/2012 11:37:54PM	10/3/2012 4:51:34AM	5Hr 14Min	
LEES009	10/2/2012 11:39:10PM	10/3/2012 4:52:34AM	5Hr 13Min	
LEES008	10/2/2012 11:44:48PM	10/3/2012 3:06:32AM	3Hr 22Min	
LEES002	10/3/2012 12:05:32AM	10/3/2012 5:34:03AM	5Hr 29Min	
LEES004	10/3/2012 12:47:16AM	10/3/2012 10:15:15AM	9Hr 28Min	
LEES010	10/3/2012 1:33:26AM	10/3/2012 4:42:30AM	3Hr 9Min	
LEES008	10/3/2012 3:55:04AM	10/3/2012 7:15:21AM	3Hr 20Min	

**Figure 58: List of the parking events at the Leon East rest area on 10/03/2012 which lasted more than 180 minutes (example report)**

- **Occupancy details:** This report provides hourly truck counts for the selected rest area and specified date range. This report is useful to retrieve the exact hourly counts for the specified period, which can then be utilized for further analysis (Figure 59).

<u>ObservationTms</u>	<u>AreaDs</u>	<u>DayOfWeek</u>	<u>HourOfDay</u>	<u>TotalOccupied</u>	<u>TotalAvailable</u>
10/03/2012	Leon Rest Area East Bound	4	0	6.00	7.00
10/03/2012	Leon Rest Area East Bound	4	1	8.00	5.00
10/03/2012	Leon Rest Area East Bound	4	2	9.00	4.00
10/03/2012	Leon Rest Area East Bound	4	3	9.00	4.00
10/03/2012	Leon Rest Area East Bound	4	4	9.00	4.00
10/03/2012	Leon Rest Area East Bound	4	5	7.00	6.00
10/03/2012	Leon Rest Area East Bound	4	6	7.00	6.00
10/03/2012	Leon Rest Area East Bound	4	7	5.00	8.00
10/03/2012	Leon Rest Area East Bound	4	8	2.00	11.00
10/03/2012	Leon Rest Area East Bound	4	9	2.00	11.00
10/03/2012	Leon Rest Area East Bound	4	10	3.00	10.00
10/03/2012	Leon Rest Area East Bound	4	11	2.00	11.00
10/03/2012	Leon Rest Area East Bound	4	12	2.00	11.00
10/03/2012	Leon Rest Area East Bound	4	13	0.00	13.00
10/03/2012	Leon Rest Area East Bound	4	14	2.00	11.00
10/03/2012	Leon Rest Area East Bound	4	15	2.00	11.00
10/03/2012	Leon Rest Area East Bound	4	16	3.00	10.00
10/03/2012	Leon Rest Area East Bound	4	17	1.00	12.00
10/03/2012	Leon Rest Area East Bound	4	18	1.00	12.00
10/03/2012	Leon Rest Area East Bound	4	19	2.00	11.00
10/03/2012	Leon Rest Area East Bound	4	20	3.00	10.00
10/03/2012	Leon Rest Area East Bound	4	21	6.00	7.00
10/03/2012	Leon Rest Area East Bound	4	22	8.00	5.00
10/03/2012	Leon Rest Area East Bound	4	23	9.00	4.00

**Figure 59: Hourly truck counts at the Leon East rest area on 10/03/2012 (example report)**

- **Occupancy prediction:** This report provides the predicted availability of truck parking spaces for the rest of the day for both, the eastbound and westbound facilities at the Leon County rest area. The details of the occupancy prediction model and this web-based report are discussed in the following chapters.

## 5.6 Cloud Integration

The truck parking data management and reporting platform described in this chapter allows for an open database environment available for connecting multiple layers of third party systems or other open database-compliant systems. Information can be fed to these different systems for dynamic reflections of truck parking activity at the Leon County rest areas.

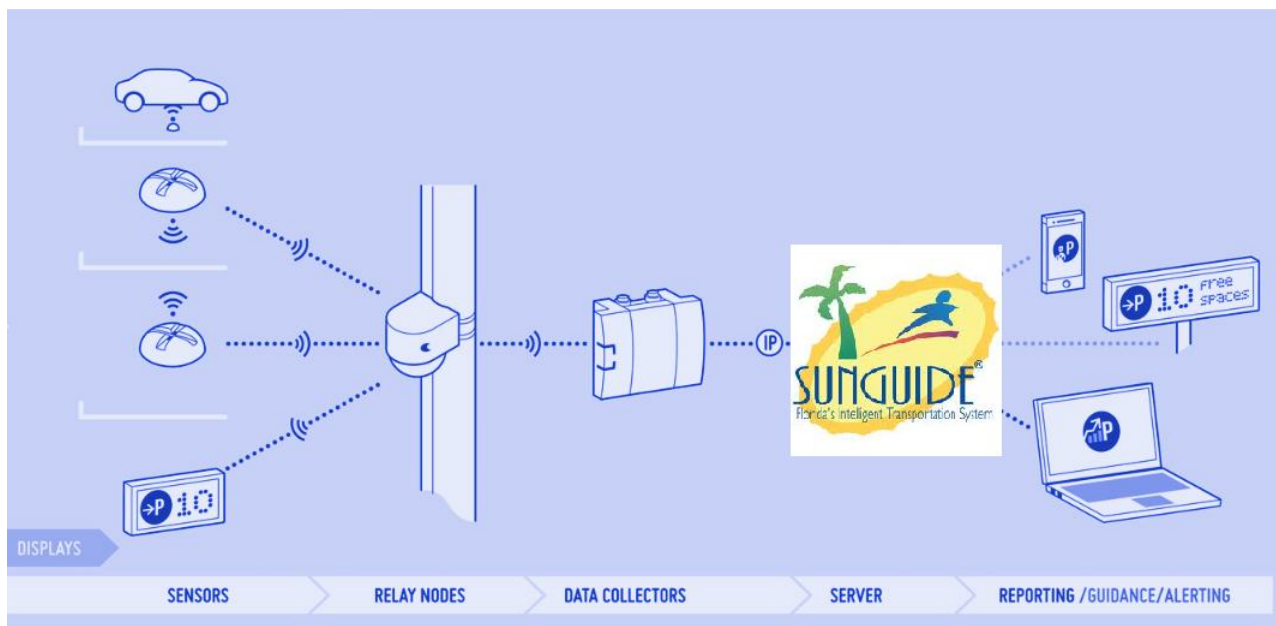

**Figure 60: Potential integration with SunGuide®**

## 6. OCCUPANCY PREDICTION MODEL

### 6.1 Introduction to Kalman Filter

The Kalman filter is named after Rudolf Emil Kalman (born 1930, Budapest, Hungary) who published a recursive solution to the discrete signal linear filtering problem in 1960 (Klette, 2006). The Kalman filter is an efficient recursive computational method to predict or estimate the state of a process. It is based on a set of mathematical equations that try to minimize the mean squared error (Welch and Bishop, 2004). A simplistic way of understanding the Kalman filter is that it works on a “prediction-correction” approach through two steps of time update and measurement update (Antoniou et al., 2007), the details of which will be discussed later in the text along with development of the model for a rest area occupancy scenario to fit the Kalman filter approach. Kalman filter is a powerful technique due to the fact that it utilizes the historical data available to estimate past and even future states. More interestingly, it can perform such a prediction even when the exact nature of the modeled system is unknown (Welch and Bishop, 2004). A description of basic concepts and further explanation of the extended Kalman filters can be read in the work of Welch and Bishop (2001, 2004) and Maybeck (1979).

The applications of Kalman filter are numerous (Klette, 2006), including:

- Tracking objects (e.g., balls, faces, heads, hands)
- Fitting Bezier patches to point data
- Economics
- Navigation
- Many computer vision applications such as:
  - Stabilizing depth measurements
  - Feature tracking
  - Cluster tracking
  - Fusing data from radar/laser scanners, and
- Stereo-cameras for depth and velocity measurement

## **6.2 Applications of Kalman Filter in Intelligent Transportation Systems (ITS)**

In addition to the aforementioned applications of Kalman filter in various fields of scientific research, it has also been utilized for certain ITS-related processes. These applications have been mainly for traffic state estimation on a corridor or at an intersection, based on data collected through either sensors or video feeds. For instance, Antoniou et al. (2007) developed a non-linear Kalman filtering algorithm using simultaneous perturbation for the computation of the gradient as a more efficient estimation method than the usual numerical derivatives. They applied the algorithm for traffic estimation and prediction purposes to the problem of on-line calibration for traffic dynamics models. Tampère and Immers (2007) used an extended Kalman filter application for traffic state estimation based on the cell transmission model (CTM). Using the extended Kalman filter in conjunction with CTM, they were able to capture rapid changes of important modeling parameters such as capacity. Veeraraghavan et al. (2005) based their work on a mixture of Kalman filters (Chen and Liu, 2000) in order to model the different motions exhibited by the target vehicles, such as slow moving or stopping, turning, accelerating, and uniform velocity motion. They utilized a “switching Kalman filter” for tracking and event detection at traffic intersections. In the case of intersections, the switching Kalman filter framework provided the advantage that, at any given time, the motion ascribed to a vehicle can be determined as a weighted combination of the three models, thereby providing more flexibility to describe their motion.

## **6.3 Rest Area Occupancy Prediction Model based on Kalman Filter**

As previously mentioned, the Kalman filter is flexible enough to be useful for various past, present, and future trend prediction estimates. The research team, considering this dynamic nature of prediction, therefore selected a Kalman filter for modeling the rest area occupancy. This was done because the research team’s aim was to employ a dynamic prediction model that uses the average historical occupancy data available for a particular time of day alongside the last hour updated occupancy count (which automatically



becomes part of the historical data). Although the updated data may not have a major impact on changing the mean occupancy that will be utilized as starting point of each prediction period, as explained later in the text, the trend of occupancy which is represented by standard deviation ( $\sigma$ ) will be affected accordingly to take into account the current day's trend. Thus, a discrete Kalman filter suited to the scenario for the rest area occupancy prediction was utilized.

The modeling of rest area occupancy prediction using a Kalman filter occurs in three steps:

1. Model Set-Up,
2. Iteration (Prediction-correction Mechanism), and
3. Application of the Model.

The model set-up will describe how the rest area occupancy prediction scenario fits in the Kalman filter methodology. The iteration process will describe the time and measurement update steps. The application of the model will describe the model considerations and period-wise estimation methodology, as well as its reasons, while providing an example of practical application to the real reliable data available through the sensors systems at the Leon County eastbound rest area. At the end, the use of prediction query from the online system will be explained.

### **Model Set-Up**

The Kalman filter addresses the general problem of trying to estimate the state of a discrete time- controlled process that is governed by the linear stochastic difference equation. It means that each  $X_k$  (number of truck present/occupancy) can be evaluated by using a linear stochastic equation. Any estimated occupancy ( $X_k$ ) is a combination of its previous value estimated plus a control signal  $U_k$  and noise. This can be represented in terms of the following equations:

$$x_k = Ax_{k-1} + Bu_k + w_{k-1}$$

With a measurement of  $z$  as

$$z_k = Hx_k + v_k$$

Where,

$x_k$  = Current estimation (*for the proposed model = predicted occupancy at time  $k$* );

$A$  = State transition matrix;

$X_{k-1}$  = Prior estimate (*for the proposed model = predicted occupancy at time  $k-1$* );

$B$  = Relates the optional control input;

$U_k$  = Control signal (control matrix);

$w$  = Random representation of the process noise;

$z_k$  = Measured value (*for the proposed model = historical average occupancy at time  $k$  updated to last hour through sensor data*);

$H$  = Matrix that relates the state to the measurement  $z_k$ ; and

$v$  = Measurement noise.

$A$  represents the state transition model (or matrix) which accounts for the change in the estimated value within a time interval. In this case, instantaneous counts are used. This means that  $X_k$  can be assumed similar to a constant signal. This is because occupancy is recorded at the start of the one-hour interval and will remain fixed until the next count is obtained at the start of the next hour. Therefore,  $A$  is assumed to be equal to 1.

It is important to note that most of the time there is no control signal (Esme, 2009). In general, control is defined as a type of influence at time  $t$  which is not inherent to the process itself (Klette, 2006). The estimations obtained here will be based on the average historical occupancy, i.e., the mean and standard deviation over an eight-hour period (as further explained later) on a similar day at the same time for which the prediction has been made.

The matrix  $H$  in the measurement equation relates the state to the measurement  $z_k$ . This might change with each time step or measurement in practice, but can be taken as

constant for the purposes of this study (Welch and Bishop, 2006). Therefore, it is assumed to be equal to 1.

The above explanation of the important parameters shows that the proposed model's requirements fit the Kalman filter prediction system. The variables remaining to be estimated are the noise functions  $W_{k-1}$  and  $v_k$ . While no real-world signal is pure Gaussian, it can nonetheless be assumed with some approximation. This is based on the fact that the Kalman Filtering Algorithm tries to converge correct estimations, even if the Gaussian noise parameters are poorly estimated (Esme, 2009). They are thus assumed to be independent of each other, with normal probability distributions; i.e.,

$$p(w) \sim N(0, Q),$$
$$p(v) \sim N(0, R).$$

In practice, the process noise covariance and measurement noise covariance matrices may change with each time step or measurement; however, it is assumed here that they are constant (Welch and Bishop, 2006). Therefore, it can be concluded from the above discussion that the scenario of occupancy prediction for rest areas fits in the Kalman filter process.

### **Iteration (Prediction-Correction Mechanism)**

It was mentioned earlier in the text that the Kalman filter basically works as a prediction-correction mechanism. Sometimes this is also referred to as “estimation through feedback.” The filter estimates the process state at a given time and then obtains feedback in the form of (noisy) measurements. The research team was able to fit its occupancy estimation scenario into the Kalman filter; i.e., having set-up the model, the next step is iteration. Kalman filter iteration equations fall into two groups, time update equations (predictor) and measurement update equations (corrector). The time update equations are responsible for projecting forward (in time) the current state and error covariance estimates to obtain the a priori estimates for the next time step. Measurement update equations are used for integrating new measurements into a previous estimate to obtain an improved a posteriori estimate (Welch and Bishop, 2006).

Figure 61 presents the completed Kalman filter process along with specific equations for the time and measurement updates (Welch and Bishop, 2006):

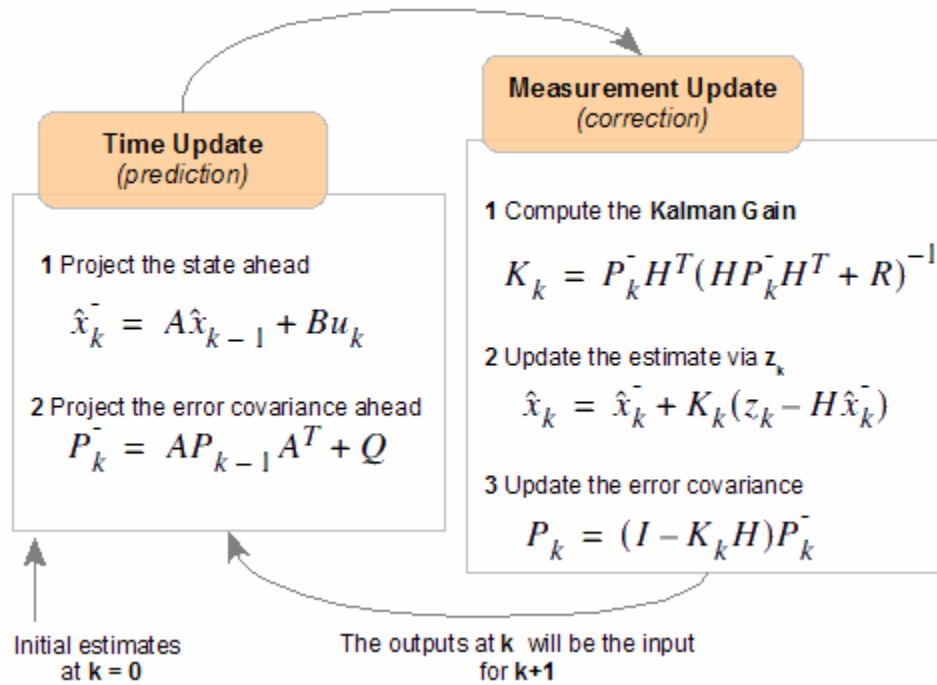

**Figure 61: Kalman filter process**

Where,

$\hat{x}_k^-$  = Prior estimate (rough estimate before the measurement update correction);

$P_k^-$  = Prior error covariance;

$\hat{x}_k$  = The estimate of  $x$  at time  $k$  (*the aim of this research*);

$P_k$  = Which is necessary for the  $k=1$  (*future*) estimate, together with  $\hat{x}_k$ ; and

$K_k$  = Kalman gain.

In the next step, the time and measurement updates will be made to real data collected through the sensor occupancy detection system installed at the Leon County rest areas. For a more comprehensive understanding of the process, the following text will describe

the application of the Kalman filter-based prediction model over a limited data period for a particular day.

### **Application of the Model**

Although the occupancy prediction at the rest area perfectly fits the Kalman filter process, it was still necessary to customize the application of the Kalman filter, as per the requirements of the rest area's occupancy in its particular scenarios. It was quite evident through the surveys of rest areas conducted in the first phase of the project that the rest area occupancy trends are influenced by the season, different days of the week, and periods within the day. Therefore, it was required that either the Kalman filter application consider such influences as inherent within the process or as control signals (external influence). The preference was given for having any such influence inherent within the process.

The seasonal influence is already inherent in the system based on the fact that, once the sensor system has collected enough data for all the seasons (at least one year of data is necessary to demonstrate a certain trend), the user of the prediction system will have the flexibility to select historical data for a specific period of the year. That data will still be updated to the last hour in order to predict the occupancy at a future point in time.

The second aspect to consider was specific day of the week. The proposed model is designed to retrieve a specific day of the week's data while making its prediction; for example, Tuesday's historical data (updated to the last hour) will be retrieved as a result of user query in order to predict occupancy at a particular time for a future time on a Tuesday. This will be more clearly explained during the section describing online prediction query.

Having addressed these issues, the most challenging task was to then define a way in which occupancy trend within a day could be utilized to keep the prediction model dynamic, based on last-hour updated data. It was thus determined that a 24-hour day be divided into different periods so that each period's rate of change could be considered

independently. The rate of change  $R$  in this case will be defined through the standard deviation of the average occupancy data. This required the team to find a realistic number of hours for defining a period in which the occupancy trend (either increasing or decreasing) remains smooth. In order to achieve this, the reliable historical data available from the sensor system from September 17, 2012 to September 30, 2012 was analyzed to find the most appropriate period in which the rate of occupancy change (defined by standard deviation) remains relatively constant. Historical average occupancy data available for weekdays Monday through Thursday was used to calculate standard deviation based on three, four, five, six, seven, and eight-hour periods. The results were plotted on a graph as shown in Figure 62. The plot provides two important inferences. First, it shows that the rate of change over a 96-hour period follows a sinusoidal pattern. This re-emphasizes that the Kalman filter can be used for modeling the prediction of occupancy. More importantly, the second inference is that the most stable trend in rate of change (represented by standard deviation) occurs within an eight-hour period and remains relatively smooth as compared to the others. As can be observed from the plot, in various periods, such as from the 8<sup>th</sup> to 15<sup>th</sup> hour of the week, the 64<sup>th</sup> hour to the 71<sup>st</sup> hour, etc., the curve for eight-hour calculation is smoother than any other curve. The prediction model therefore makes a prediction for every hour, considering the hourly updated data for each eight-hour standard deviation, taking the eight-hour mean as the starting point for each period. Hence, any seasonal, day of the week, or hour of the day-related influences are inherent in the process itself. Also, the historical data is being updated dynamically (continuously) each hour. All of these facts imply that we do not have any external influence in this case. As such, the control ( $u_k$ ) can be taken as equal to zero.

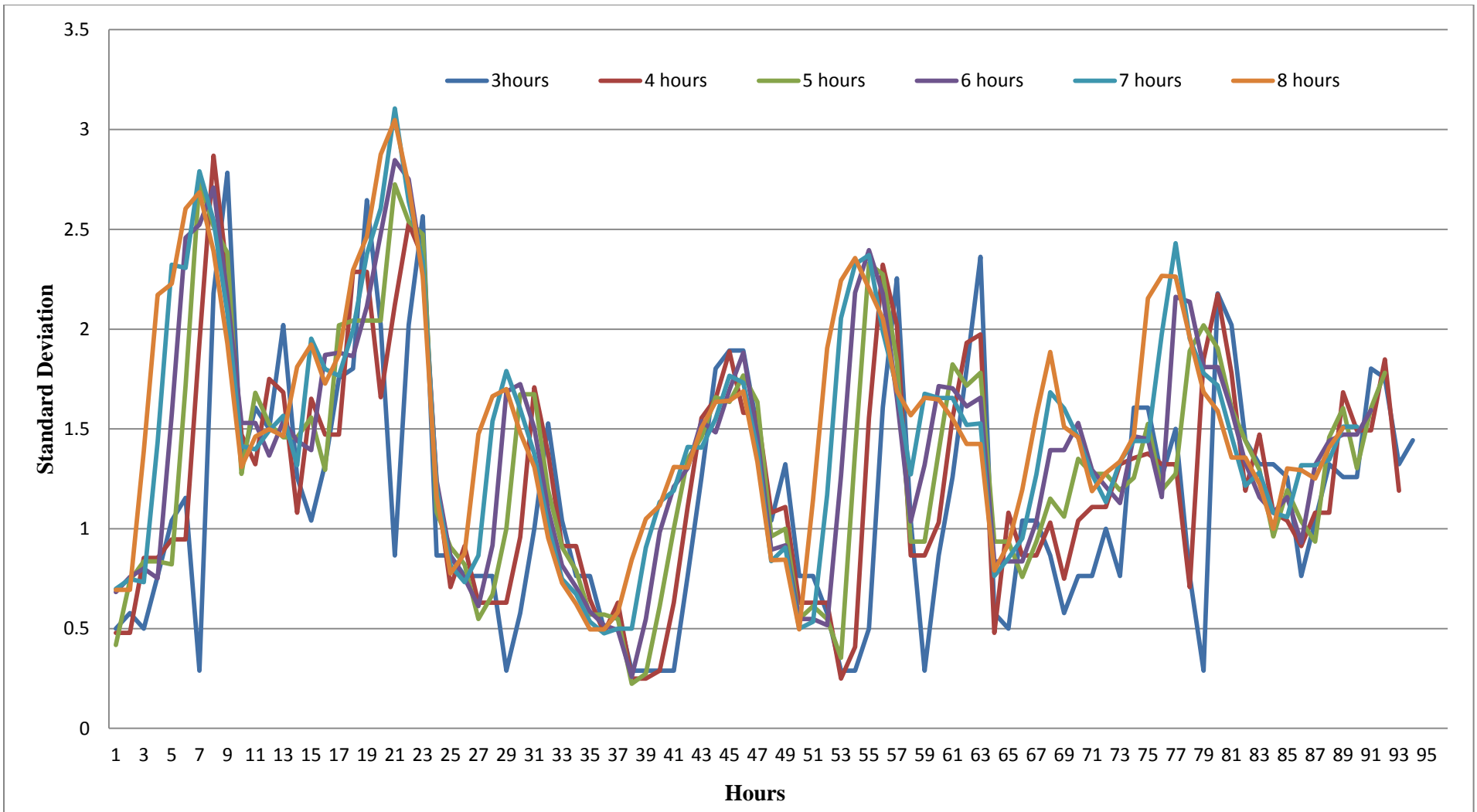

**Figure 62: Standard deviation of historical occupancy data based on three, four, five, six, seven, and eight-hour periods**

### Example Application

Table 3 shows the hourly average occupancy data for Mondays between the aforementioned reliable data period obtained through the sensor system.

**Table 3: Average hourly occupancy data for Mondays**

<b>Time (<math>k</math>)</b>	<b>Average Occupancy (<math>Z_k</math>)</b>
0	8.5
1	8
2	9
3	8
4	8.5
5	7
6	9
7	9
8	8.5
9	5
10	3
11	5.5
12	2.5
13	4
14	6.5
15	5
16	4.5
17	2.5
18	6
19	5
20	1
21	2.5
22	2.5
23	6

As mentioned earlier,

- No such control signal  $u_k$  is given;
- $A = 1$ ; and
- $H = 1$ .



The initial state can be defined as  $(K_o, X_o, P_o)$ , while in this case they are taken as follows:

$K = 0$  (12:00 AM);

$X_o = \hat{x}_{k-1}$  = Mean of average occupancy for the respective eight-hour period; and

$P_o = 1$  (assuming that there was some noise/turbulence in the system).

Thus, the time update and measurement update equation can be written as shown below.

Time Update (prediction)	Measurement Update (correction)
$\hat{x}_k^- = \hat{x}_{k-1}$ $P_k^- = P_{k-1}$	$K_k = \frac{P_k^-}{P_k^- + R}$ $\hat{x}_k = \hat{x}_k^- + K_k(z_k - \hat{x}_k^-)$ $P_k = (1 - K_k)P_k^-$

Next, the  $\hat{x}_k$  value for the first group of iterations in the first eight-hour period is calculated.

For First Iteration	For Second Iteration
$Z_k = 8.5$ $\hat{x}_{k-1} = 8.38$ $P_k^- = 1$ $R = \sigma = 0.69$ (for first eight-hour period)	$Z_k = 8$ $\hat{x}_{k-1} = 9$ $P_k^- = 1$ $R = \sigma = 0.69$ (for first eight-hour period)
Time Update $\hat{x}_k^- = \hat{x}_{k-1} = 8.38$ $P_k^- = P_{k-1} = 1$	Time Update $\hat{x}_k^- = \hat{x}_{k-1} = 9$ $P_k^- = P_{k-1} = 0.41$

<p>Measurement Update</p> $K_k = 1/(1+0.69) = 0.59$ $P_k = (1-0.59) \times 1 = 0.41$ $\hat{x}_k = 8.38 + 0.59(8.5-8.38) = 8.45 \text{ (rounded up to 9)}$	<p>Measurement Update</p> $K_k = 0.41/(0.41+0.69) = 0.37$ $P_k = (1-0.37) \times 0.41 = 0.26$ $\hat{x}_k = 9 + 0.37(8-9) = 8.63 \text{ (rounded up to 9)}$
---	--

The resulting iterations for the remaining hours are shown Table 4.

**Table 4: Kalman filter iterations**

Time ( $k$ )	Occupancy ( $Z_k$ )	$X_{(k-1)}$	$P_k'$	Time update ( $X_k'$ )	Measurement Update		
					$K_k$	$X_k$	$P_k$
0	8.50	8.38	1.00	8.38	0.59	9.0	0.4
1	8.00		0.4	9.00	0.37	9.0	0.26
2	9.00		0.26	9.00	0.27	9.0	0.19
3	8.00		0.19	9.00	0.21	9.0	0.15
4	8.50		0.15	9.00	0.18	9.0	0.12
5	7.00		0.12	9.00	0.15	9.0	0.10
6	9.00		0.10	9.00	0.13	9.0	0.09
7	9.00		0.09	9.00	0.12	9.0	0.08
$\mu$	8.38						
$\sigma$	0.69						
8	8.50	5.00	0.08	5.00	0.04	6.00	0.08
9	5.00		0.08	6.00	0.04	6.00	0.07
10	3.00		0.07	6.00	0.04	6.00	0.07
11	5.50		0.07	6.00	0.04	6.00	0.07
12	2.50		0.07	6.00	0.03	6.00	0.07
13	4.00		0.07	6.00	0.03	6.00	0.06
14	6.50		0.06	6.00	0.03	7.00	0.06
15	5.00		0.06	7.00	0.03	7.00	0.06
$\mu$	5.00						
$\sigma$	1.93						
16	4.50	3.75	0.06	3.75	0.03	4.00	0.06
17	2.50		0.06	4.00	0.03	4.00	0.06
18	6.00		0.06	4.00	0.03	5.00	0.05
19	5.00		0.05	5.00	0.03	5.00	0.05
20	1.00		0.05	5.00	0.03	5.00	0.05
21	2.50		0.05	5.00	0.03	5.00	0.05
22	2.50		0.05	5.00	0.03	5.00	0.05
23	6.00		0.05	5.00	0.03	6.00	0.05
$\mu$	3.75						
$\sigma$	1.87						

The results of the predicted occupancy, along with the historical hourly average occupancy, are plotted and shown in Figure 63.

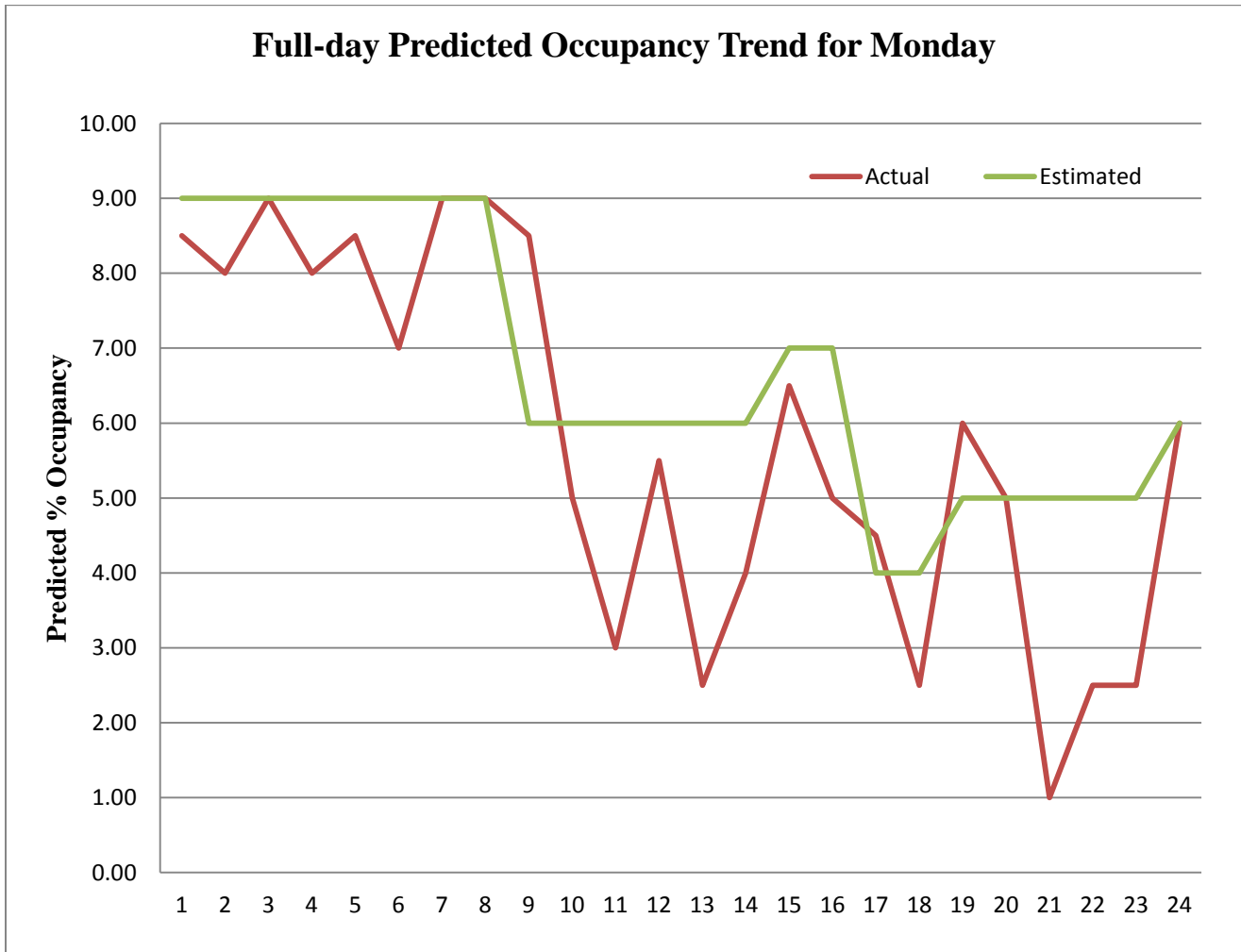

**Figure 63: Predicted occupancy versus actual occupancy**

Figure 63 shows that the predicted curve follows the same trend as that of the actual curve while erring on the safer side of occupancy prediction. This will allow the model to account for any realistic counts that have been missed (if any) during the one-hour interval because the prediction is based on discrete data.

## 6.4 Evaluation of Prediction Accuracy

The Kalman filter approach described in the previous section facilitates prediction in a dynamic scenario (created by factors such as the season, time of the day, etc.) based on up-to-date historical data. This section presents a comparative Root Mean Squared Error (RMSE) analysis between the Kalman filter model and the linear regression model. First, the development of the regression model for the purpose of accuracy evaluation is discussed followed by a comparison between the Kalman filter model and the linear regression model based on RMSE analysis. The data used for this comparison was acquired from the Leon County rest area (westbound).

### Development of the Linear Regression Model

Historical average occupancy data from September 16, 2012 to November 23, 2012 was used to develop a total of 12 linear regression models, one for each of the twelve 8-hour periods between Mondays to Thursdays. The data utilized for the development of the regression model and the related predictions for Monday between hour-0 to hour-7 is shown in Table 5. Figure 64 shows the regression curve for the same period. The data tables and graphs showing the regression curves for the remaining periods are included in Appendix B.

**Table 5: Regression model prediction (example)**

<b>Rest Area</b>	Leon County West bound	
<b>Day</b>	Monday	
<b>Regression Model Equation</b>	$y = 0.152x + 8.6142$ y = Predicted Occupancy x = hour of day	
<b>Hour of Day</b>	<b>Occupancy</b>	
	<b>Average</b>	<b>Predicted</b>
0	7.73	9
1	8.91	9
2	9.36	9
3	9.45	9
4	9.73	9
5	9.45	9
6	9.45	10
7	9.09	10

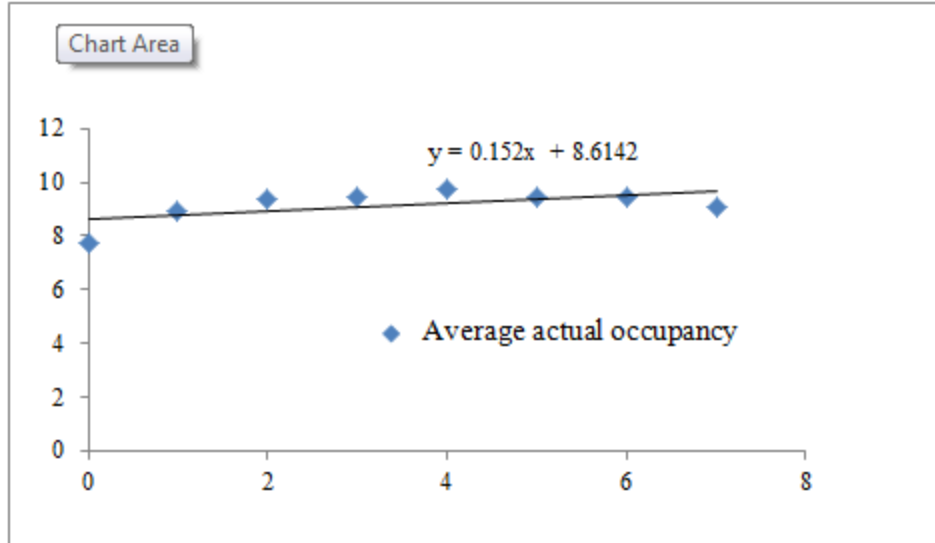

**Figure 64: Regression curve (example)**

### **Root Mean Squared Error (RMSE) Analysis**

Root Mean Squared Error (RMSE) basically provides estimate of error variance. The normal variance measures the distance from the mean of a data set. However, RMSE measures the variance from 0, which should be an ideal error for any prediction. RMSE can be computed by taking the sum of the squares of the errors (difference between the predicted and actual values), computing the average and then taking the square root. The related equation is as follows:

$$RMSE = \sqrt{\frac{\sum (\text{predicted occupancy} - \text{actual occupancy})^2}{\text{No. of hours in the prediction period (i.e.8)}}$$

The historical average occupancy data from September 16, 2012 to November 23, 2012 was used to predict occupancy at the Leon County rest area (westbound) from Monday, November 26, 2012 to Thursday, November 29, 2012 using the Kalman filter based prediction tool available on the online system. Same predictions were also made using the linear regression models developed. Furthermore, the actual occupancy data from the sensor system was retrieved from the online system. The errors in the predictions from both prediction models were calculated to find out RMSE for each 8-hour prediction periods within the 96 hours from Monday, November 26, 2012 to Thursday, November 29, 2012. The detailed tables showing the RMSE calculations

are presented in Appendix C. Table 6 shows the RMSE values calculated for both the prediction models. Figure 65 shows RMSE curves for both the prediction models in order to compare their prediction accuracy.

**Table 6: The calculated RMSE values**

<b>8-hr periods</b>	<b>RMSE (Regression model)</b>	<b>RMSE (Kalman Filter model)</b>
0 to 7	3.156726	2.263846
7 to 15	1.985433	3.122499
15 to 23	1.553028	1.322876
24 to 31	2.037111	1.767767
32 to 39	3.588259	3.297726
40 to 47	11.56775	2.715695
48 to 55	1.639166	0.935414
56 to 63	1.993863	1.732051
64 to 71	9.66491	1.541104
72 to 79	1.964134	2.872281
80 to 87	2.358649	1.870829
88 to 95	6.883816	1.767767

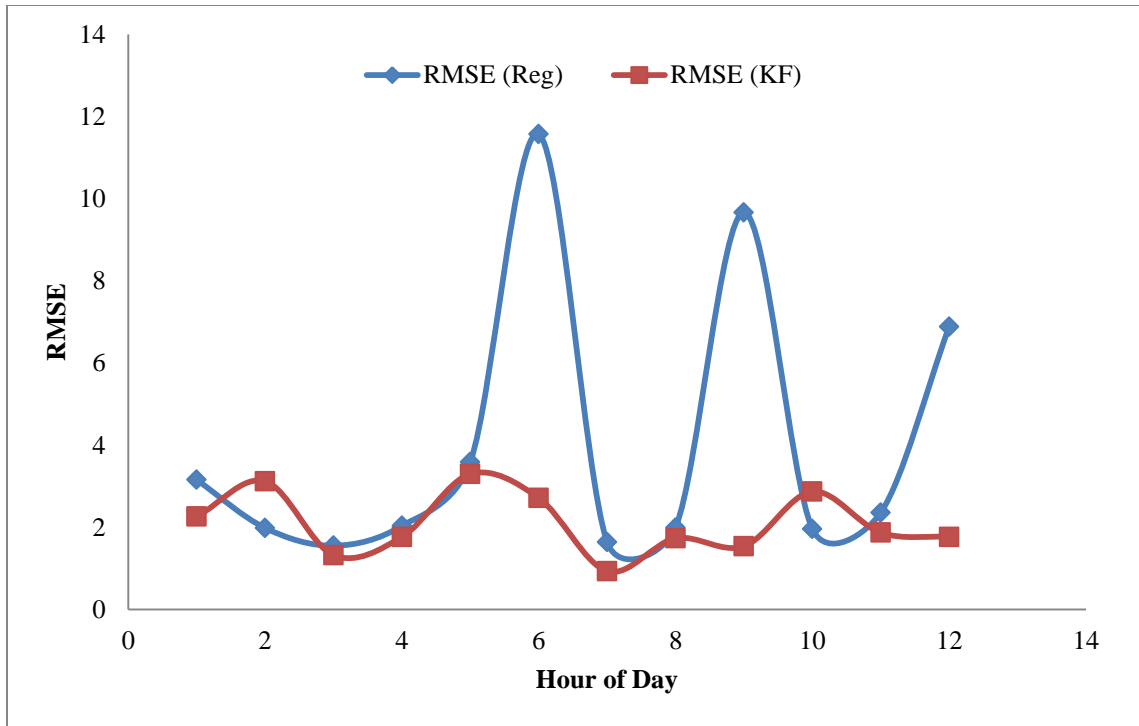

**Figure 65: RMSE curves**

The RMSE curves in Figure 65 clearly show that prediction error is significantly less for the Kalman filter model as compared to the regression based model in almost every hour of the day for the studied prediction period. Thus, Kalman filter based prediction model performs better than regression model. This conclusion seconds and adds further rationale for using Kalman filter to that presented in the model development section. It is also worth mentioning that as time goes by and more data is added to the system, the Kalman filter based prediction model will improve its performance further, simply because of time-measurement update mechanism.



## 6.5 Web-based Occupancy Prediction Query

The Web-based system for the prediction query has been designed with a very easy-to-use interface. The user is not required to provide any input (Figure 66). After the user clicks the “Print Report” button, the system generates a report which contains the predicted availability of truck parking spaces for the rest of the day for both, the eastbound and westbound facilities at the Leon County rest area.

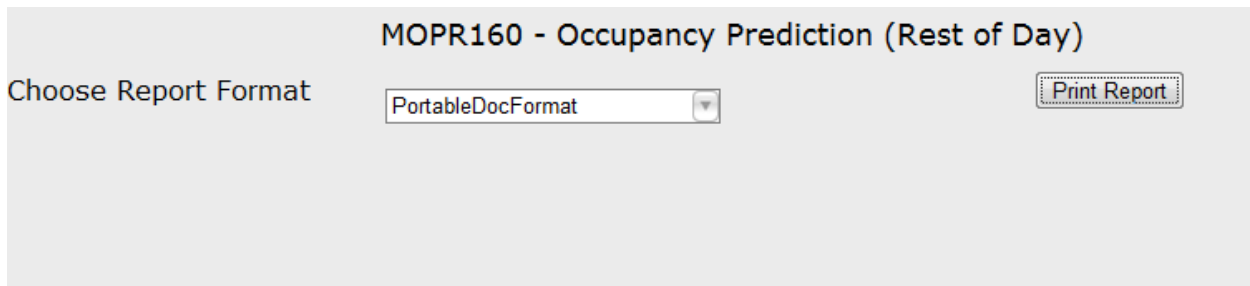

MOPR160 - Occupancy Prediction (Rest of Day)

Choose Report Format

PortableDocFormat

Print Report

**Figure 66: Web-based occupancy prediction query**

The developed Kalman filter model is integrated with the dynamic database of the wireless vehicle detection system. When the user prints a report, the query automatically extracts average occupancy data (including the last hour’s readings) for that particular weekday and completes the required calculations as described in Section 6.3.

Figure 67 shows an example prediction report generated on Wednesday, December 05, 2012 at 1:44 PM. The report provides predicted available parking spaces for the rest of the day from 2:00 PM to 11:00 PM in both facilities.

## MOPR160 - Occupancy Prediction (Rest of Day)

Current Date / Time: 12/5/2012 1:44PM

This report provides predicted availability of truck parking spaces for the rest of the day

Rest Area: Leon Rest Area East Bound

<u>Time</u>	<u>Predicted Available Spaces</u>
2:00PM	5
3:00PM	5
4:00PM	5
5:00PM	5
6:00PM	5
7:00PM	5
8:00PM	5
9:00PM	5
10:00PM	6
11:00PM	7

Rest Area: Leon Rest Area West Bound

<u>Time</u>	<u>Predicted Available Spaces</u>
2:00PM	8
3:00PM	8
4:00PM	7
5:00PM	7
6:00PM	7
7:00PM	7
8:00PM	7
9:00PM	7
10:00PM	8
11:00PM	9

Figure 67: Occupancy prediction report (example)

# CONCLUSIONS

## 7.1 Summary

This research sought to understand the truck parking problem in Florida, determine the supply and demand characteristics for commercial truck parking, assess technology that can be used to improve parking management, and conduct a pilot project for a smart truck parking management to increase operational efficiency of commercial drivers and reduce trucks parking on shoulders, crashes due to driver fatigue, and unnecessary diesel emissions. The major objectives of this research included: i) Phase-1: to determine trends for truck parking at rest areas and weigh stations throughout Florida and ii) Phase-2: to develop a suitable smart parking management system for commercial motor vehicles and conduct a pilot project.

The specific objectives of Phase-1 included: (i) to determine the supply characteristics of commercial truck parking facilities along interstate highways in Florida; (ii) to determine the demand characteristics of commercial truck parking facilities along interstate highways in Florida; (iii) to determine facilities that are being used and to what capacity; and (iv) to determine current shortfalls in the supply of commercial truck parking spaces along interstate highways in Florida. Phase-1 involved collection of field observation data by the research team at all of the public rest areas along the I-10, I-75, and I-95 corridors. The data collection efforts in Phase-1 enabled the research team to determine the level of truck parking capacity problem experienced at each rest area. This information was used to divide the rest areas into three categories, low, medium, and high, based on the “level of truck parking capacity problem,” and depicted the rest areas on a color-coded map for I-10, I-75, and I-95; green was used for a low parking capacity problem, yellow for a medium parking capacity problem, and red for a high parking capacity problem.

Phase-2 of this research project included an assessment of technology that can be used to improve truck parking management at rest areas in Florida and deploy a pilot project to test implementation. The vehicle detection technology chosen for the pilot project at the Leon County rest areas (eastbound and westbound) on I-10 features wireless ground sensors, which

detect the presence of a vehicle as it comes to a stop above it. The actual occupancy determination is accomplished using a unique combination of differential magnetic induction measuring with a built-in infrared sensor. This combination technology allows the sensors to accurately determine the presence of a high-clearance truck chassis without confusing it with another vehicle parked in an adjacent space. The sensors are communicating through a network of wireless mesh repeaters, which relay information to data collectors on the premises. The data collectors in turn are connected to a central database via the Internet. Informational maps, historical data reports, and a number of other applications can be accessed by the user, along with other shared data platforms and devices, such as smart phones.

Over the course of this research, various software tools were developed to complement the wireless vehicle detection system described above, including a GIS mapping application, a report generation module, and an occupancy prediction model. The GIS mapping application developed for the pilot project represents an easy to read site map that offers a real-time feed of the sites' truck parking information. The report generation module offers immediate access to historical truck parking data collected from the truck parking facilities. The occupancy prediction model utilizes the Kalman filter to provide the user with a prediction of available parking spaces at a specified date and time provided by the user.

## **7.2 Advantages of the Tested Wireless Vehicle Detection System**

The wireless vehicle detection system tested over the course of this research has a number of benefits over other competing technologies, such as video cameras, vehicle entry/exit counters, etc.:

- Significantly lower capital and maintenance costs.
- Improved accuracy.
- Increased reliability.

### **7.3 Recommendations for Future Research**

- **Better Utilization of Weigh Stations for Nighttime Truck Parking**

One of the observations of the research team in Phase-1 of the project is that the truck drivers are hesitant to use weigh stations for nighttime truck parking. Better utilization of weigh stations for nighttime truck parking could be an immediate improvement to dealing with truck parking demands in Florida. The objective of further research would be (i) to determine the reasons as to why truck drivers are not willing to use weigh stations for nighttime parking and (ii) to develop recommendations for FDOT to address this problem.

- **Pilot Study to Develop a Comprehensive Truck Stop Database in Florida**

Evidence shows that most of the spaces available for trucks are located in private truck stops. In many cases, truck drivers could benefit from accurate information regarding the location of private truck stops in addition to public rest areas. The objective of further research would be to identify a pilot project area in Florida (e.g., one of the segments identified in Phase-1 of the study to include rest areas with significant truck parking capacity problems) and develop a “truckers’ map/guide” that identifies the location of both public rest areas and private truck stops in the pilot study area. If successful, this study could be implemented statewide to develop a comprehensive database of public and private truck stops in Florida.

- **Evaluation of Public-Private Partnerships Opportunities for Florida’s Rest Areas and Truck Stops**

FDOT could potentially fund the cost of rest area maintenance and operations and/or increase truck parking capacity by entering into a public-private partnership (PPP) contract with the private sector. The objective of further research would be to identify successful PPP cases in other states with respect to rest areas and truck stops. This would be done through a thorough review of published literature (DOT reports; news article, academic publications, etc.) as well survey of relevant DOT personnel and private companies to gather further information regarding successful partnerships that are

currently underway. Also, PPP cases in states such as Utah, Virginia, California, Georgia, and Connecticut would be studied and different forms of PPP agreements for rest areas would be identified. The research team would then identify potential PPP opportunities for rest areas in Florida based on the synthesis discussed above and the research team's own experience from Phase-1 of this research.

## REFERENCES

- Adams, D. and Reiersen J. (1981). "Safety Rest Areas: Planning, Location and Design." In *Transportation Research Record: Journal of the Transportation Research Board*, No. 822, Transportation Research Board of the National Academies, Washington, D.C., 1981, pp. 1-6.
- Antoniou, C., Koutsopoulos, H.N., and Yannis, G. (2007). "An efficient non-linear Kalman filtering algorithm using simultaneous perturbation and applications in traffic estimation and prediction." Proceedings of the 2007 IEEE Intelligent Transportation Systems Conference Seattle, WA, USA, Sept. 30 - Oct. 3, 2007, pp. 217-222.
- Al-Kaisy A., Church B., Veneziano D., and Dorrington C. (2010). "Investigation of Parking Dwell Time at Rest Areas on Rural Highways", Transportation Research Board 90th Annual Meeting January 23-27, 2011.
- ATRI, (1996). "Commercial Driver Rest and Parking Requirements: Making Space for Safety." U.S. Department of Transportation Federal Highway Administration. Report No. FHWA-MC 96-0010. May 1996.  
<<http://www.fhwa.dot.gov/publications/research/safety/commercial.pdf>>(October 2012).
- Banerjee I., Lee, J.H., Jang, K., Pande, S. and Ragland, D. (2009). "Rest Areas – Reducing Accidents Involving Driver Fatigue." Report No: CA 09/1092, Prepared for CALTRANS. <<http://cdm16255.contentdm.oclc.org/cdm/singleitem/collection/p266401coll4/id/4711/rec/11>> (October 2012).
- Byrne, B. (1991). "Usage of Three Rest Areas in Vermont." In *Transportation Research Record: Journal of the Transportation Research Board* No. 1326, Transportation Research Board of the National Academies, Washington D.C., 1991, pp. 6-10.
- Cambridge Systematics, Inc. (CS). (2007). *Florida Statewide Freight and Goods Mobility Plan*. Report prepared for Florida Department of Transportation, Seaport Office, Cambridge Systematics, Inc., Fort Lauderdale, Florida, USA, June 2007.
- Chen, R., and J.S. Liu. (2000). "Mixture Kalman Filters." *Journal of Royal Statistical Society Series-B Statistical Methodology*, 62 (Part 3): 493-508.
- Connecticut DOT. (2008). "CT Statewide Rest Area and Service Plaza Study- Volume I – Administrative Report – Recommended Improvement Program" CONN DOT Project No. 170-2533.  
< [http://www.ct.gov/dot/lib/dot/documents/dpolicy/restarea/master\\_voli.pdf](http://www.ct.gov/dot/lib/dot/documents/dpolicy/restarea/master_voli.pdf)> (October 2012).
- Esme, B. (2009). "Kalman Filter for Dummies-A Mathematically Challenged Man's Search for Scientific Wisdom." <<http://bilgin.esme.org/BitsBytes/KalmanFilterforDummies.aspx>> (October 2012).
- Fleger, S., Haas, R. Trombly, J., Cros III, R., Noltenius, J., Pecheux, K., and Chen, K. (2002). "Study of Adequacy of Commercial Truck Parking Facilities – Technical Report." FHWA-RD-01-158, March 2002.
- FMCSA. (2007). "SmartPark Real-Time Parking Information for Truckers" <<http://www.fmcsa.dot.gov/facts-research/art-technology-SmartPark-Real-Time.htm>> (September 2012).

Gårder P.E. and Bosonetto N. (2002). “Quantifying roadside rest area usage.” Report No: NETCR 38, Project No. 99-4, Prepared for New England Transportation consortium (NETC)  
< <http://docs.trb.org/00941461.pdf>> (September 2012).

Gates J.T., Savolainen P.T., Datta T.K., Ryan G., Todd R.G. and Boileau S. (2012) “Evaluating the Appropriate Level of Service for Michigan Rest Areas and Welcome Centers Considering Safety and Economic Factors.” Report No. RC-1570, Prepared for MDOT.  
< [http://www.michigan.gov/documents/mdot/MDOT\\_Research\\_Report\\_RC1570\\_387400\\_7.pdf](http://www.michigan.gov/documents/mdot/MDOT_Research_Report_RC1570_387400_7.pdf)> (September 2012).

Havinoviski, G.N., Taylor, R.V., Johnston, A., and Kopp, J.C. (2000). Real-time parking management systems for park-and-ride facilities along transit corridors. In *Intelligent Transportation Systems America Proceedings* (10th Washington, D.C) 2000. pp16

King, G.F. (1989). “*Evaluation of Safety Roadside Rest Areas.*” National Cooperative Highway Research Program Report 324, December 1989.

Klette, R. (2006). “The Kalman Filter.” Course notes, Subject MI37, course note  
<<http://www.cs.auckland.ac.nz/~rklette/TeachAuckland.html/mm/MI37slides.pdf>> (October 2012).

Maybeck, P.S. (1979). Stochastic models, estimation, and control, volume 1, chapter 1, Introduction, pp.1-16. Academic Press.

Melton, W., A. Tran and J. Levenson (1989). “*Rest Area Usage Design Criteria Update.*” Washington State Department of Transportation, Olympia, Washington, January 1989.

MnDOT. (1998). “Commercial Truck Usage Nighttime Parking Demand Analysis February 1995-October 1998”  
<<http://www.dot.state.mn.us/restareas/pdf/research/nighttime-parking-demand.pdf>> (October 2012).

MnDOT. (2001). “Nighttime Commercial Vehicle Parking Demand at 15 high-Use Minnesota Rest Areas.” < <http://www.dot.state.mn.us/restareas/pdf/research/nighttime-parking-demand-15sites.pdf>> (October 2012).

National Cooperative Highway Research Program (NCHRP) Synthesis 317. (2003). “Dealing with Truck Parking Demands.” Transportation Research Board, Washington, D.C., 2003.

Nebraska Department of Roads. (1987). “*Nebraska Safety Rest Area Study Number 4.*” Nebraska Department of Roads, Lincoln, Nebraska, 1987.

North Jersey Transportation Planning authority. (2008). “An assessment of potential locations for truck rest areas in Northern New Jersey and the Port district.” < <http://www.njtpa.org/plan/element/freight/documents/truckstop.pdf>> (September 2012).

Perfater, Michael A. (1989). “Operation and Motorist Usage of Interstate Rest Areas and Welcome Centers in Virginia. In *Transportation Research Record: Journal of the Transportation Research Board* No. 1224, Transportation Research Board of the National Academies, Washington D.C., 1989, pp. 46-53.

Smith S.B., Baron W., Gay K. and Ritter G. (2005). “Intelligent Transportation Systems and Truck Parking” Federal Motor Carrier Safety Administration, Report no. FMCSA-RT-05-001



<<http://www.fmcsa.dot.gov/facts-research/briefs/intelligent-transportation-truckparking.pdf>> (September 2012).

Tampère, C.M.J. and Immers, L.H. (2007). "An Extended Kalman Filter Application for Traffic State Estimation Using CTM with Implicit Mode Switching and Dynamic Parameters." Intelligent Transportation Systems Conference (ITSC 2007), IEEE, Sept. 30 2007-Oct. 3 2007, PP 209-216.

Twardzik, L. and Haskell, T. (1985). "*Rest Area/Roadside Park Administration, Use and Operations*. Michigan State University, Lansing, Michigan, June 1985.

U.S. Department of Transportation (DOT). (2000). Federal Motor Carrier Safety Administration. *49 CFR Parts 350, et al. Hours of Service of Drivers; Driver Rest and Sleep for Safe Operations; Proposed Rule*. Federal Register, National Archives and Records Administration, Washington, D.C., May 2, 2000.

Veeraraghavan, H., Schrater, P., and Papanikolopoulos, N. (2005). "Switching Kalman Filter-Based Approach for Tracking and Event Detection at Traffic Intersections." Proceedings of the 13th Mediterranean Conference on Control and Automation Limassol, Cyprus, June 27-29, 2005, pp 1167-1172.

Welch, G., and Bishop, G. (2006). "An introduction to the Kalman Filter." Course notes 8, University of North Carolina at Chapel Hill, Department of Computer Science. <[http://www.cs.unc.edu/~welch/media/pdf/kalman\\_intro.pdf](http://www.cs.unc.edu/~welch/media/pdf/kalman_intro.pdf)> (October 2012).

## APPENDIX A

### Technical Specifications for Mesh Network Components

SENSIT (US and Canada)		9898760
Operating frequency	902-928 MHz (FHSS)	
	FCCID: CGDSENSDATA IC: 1444A-SENSDATA	
Dimensions	Ø 80 mm (3.15 inch) and 70 mm (2.8 inch)	
Weight	365 g (12.87oz)	
Protection	IP67, completely sealed housing	
Material	Black Polyethylene	
Operational temperature	-20 °C ... +85 °C (-4 °F ... +185 °F)	
Storage temperature	-20 °C ... +85 °C (-4 °F ... +185 °F)	
Communication range	From sensor to sensor >10m (33 feet)	Dependent on the environment
Power supply	Built-in lithium battery	Expected battery life 5 years
Mounting	Into the floor of a parking space	
Detection	Magnetic	
Detection height	90 cm (35.5 inch)	

RELAY NODE (US and Canada)		
Operating frequency	902-928 MHz (FHSS)	
	FCCID: CGDSENSDATA IC: 1444A-SENSDATA	
Dimensions	Ø 80 mm (3.15 inch) and 70 mm (2.8 inch)	
Weight	365 g (12.87oz)	
Protection	IP67, completely sealed housing	
Material	Black Polyethylene	
Operational temperature	-20 °C ... +85 °C (-4 °F ... +185 °F)	
Storage temperature	-20 °C ... +85 °C (-4 °F ... +185 °F)	
Communication range	From RELAY NODE to RELAY NODE > 50m (or 150 feet)	Dependent on the environment
Power supply	Built-in lithium battery	Expected battery life 3 years
Mounting	On a pole or wall	metal bracket included

SENSIT DATACOLLECTOR (EU)		9889582
Operating frequency	868.2 MHz	
CE compliant	EN 60950-1 EN50357 and EN 50364 EN 301 4889-1 V1.6.1 and EN 301 489-3 V1.4.1 EN 61000-6.1, EN 61000-6-2 and 61000-6-3 EN 55011 Class B EN 61204-3 EN 300-220-1 ERV REC 70-03	
Dimensions	150 x 82 x 49 mm (5.9 x 3.26 x 1.9 inch)	
Weight	105 gr. (0.7 oz)	
Protection	IP44	
Colour	Grey according to RAL 7035	
Operating temperature	-20 °C ... +85 °C (-4 °F ... +185 °F)	
Storage temperature	-20 °C ... +85 °C (-4 °F ... +185 °F)	
Communication range	From SENSIT to DATACOLLECTOR in principle unendless as the SENSITS communicate to each other. It is recommended to locate the nearest RELAY NODE or SENSIT within 25 meters (82 ft) of the DATACOLLECTOR.	Dependent on the environment.  You can install multiple DATACOLLECTORS in one parking facility.
Communication interfaces	RJ-45, TCP/IP or SUB-D9, RS232	
Humidity	10%...90% relative humidity, non condensing	
Outputs	I2C interface for future use	
Power input	5 VDC	Separate adapter supplied for 110-240 VAC.
Antenna connection	Antenna included	

## APPENDIX B

### Root Mean Squared Error Calculations

*Root Mean Squared Error Calculations (Kalman Filter Model)*

Rest Area	Day Of Week	Hour Of Day	Predicted Occupancy	Actual Occupancy	Error	Error <sup>2</sup>	RMSE
LEONWEST	2	0	10	12	-2	4	
LEONWEST	2	1	10	13	-3	9	
LEONWEST	2	2	10	13	-3	9	
LEONWEST	2	3	10	13	-3	9	
LEONWEST	2	4	10	12	-2	4	
LEONWEST	2	5	10	11	-1	1	
LEONWEST	2	6	10	12	-2	4	
LEONWEST	2	7	10	11	-1	1	<b>2.263846</b>
LEONWEST	2	8	6	9	-3	9	
LEONWEST	2	9	7	5	2	4	
LEONWEST	2	10	7	3	4	16	
LEONWEST	2	11	7	4	3	9	
LEONWEST	2	12	7	5	2	4	
LEONWEST	2	13	7	3	4	16	
LEONWEST	2	14	7	3	4	16	
LEONWEST	2	15	7	5	2	4	<b>3</b>
LEONWEST	2	16	7	7	0	0	
LEONWEST	2	17	7	7	0	0	
LEONWEST	2	18	7	5	2	4	
LEONWEST	2	19	7	4	3	9	
LEONWEST	2	20	7	7	0	0	
LEONWEST	2	21	8	8	0	0	
LEONWEST	2	22	9	8	1	1	
LEONWEST	2	23	10	10	0	0	<b>1.322876</b>
LEONWEST	3	0	12	10	2	4	
LEONWEST	3	1	13	13	0	0	
LEONWEST	3	2	13	12	1	1	
LEONWEST	3	3	13	12	1	1	
LEONWEST	3	4	13	13	0	0	
LEONWEST	3	5	13	12	1	1	
LEONWEST	3	6	13	10	3	9	
LEONWEST	3	7	13	10	3	9	<b>1.767767</b>

Space	Day Of Week	Hour Of Day	Predicted Occupancy	Actual Occupancy	Error	Error <sup>2</sup>	RMSE
LEONWEST	3	8	6	5	1	1	
LEONWEST	3	9	7	4	3	9	
LEONWEST	3	10	7	2	5	25	
LEONWEST	3	11	7	3	4	16	
LEONWEST	3	12	7	2	5	25	
LEONWEST	3	13	7	6	1	1	
LEONWEST	3	14	7	6	1	1	
LEONWEST	3	15	7	4	3	9	<b>3.297726</b>
LEONWEST	3	16	7	5	2	4	
LEONWEST	3	17	7	5	2	4	
LEONWEST	3	18	7	5	2	4	
LEONWEST	3	19	7	5	2	4	
LEONWEST	3	20	7	4	3	9	
LEONWEST	3	21	7	10	-3	9	
LEONWEST	3	22	8	11	-3	9	
LEONWEST	3	23	9	13	-4	16	<b>2.715695</b>
LEONWEST	4	0	12	13	-1	1	
LEONWEST	4	1	13	13	0	0	
LEONWEST	4	2	13	13	0	0	
LEONWEST	4	3	13	13	0	0	
LEONWEST	4	4	13	13	0	0	
LEONWEST	4	5	13	12	1	1	
LEONWEST	4	6	13	12	1	1	
LEONWEST	4	7	13	11	2	4	<b>0.935414</b>
LEONWEST	4	8	7	6	1	1	
LEONWEST	4	9	8	6	2	4	
LEONWEST	4	10	8	6	2	4	
LEONWEST	4	11	8	6	2	4	
LEONWEST	4	12	8	7	1	1	
LEONWEST	4	13	8	7	1	1	
LEONWEST	4	14	8	8	0	0	
LEONWEST	4	15	8	11	-3	9	<b>1.732051</b>
LEONWEST	4	16	7	8	-1	1	
LEONWEST	4	17	7	7	0	0	
LEONWEST	4	18	7	6	1	1	
LEONWEST	4	19	7	5	2	4	
LEONWEST	4	20	7	7	0	0	
LEONWEST	4	21	7	7	0	0	
LEONWEST	4	22	8	5	3	9	

Space	Day Of Week	Hour Of Day	Predicted Occupancy	Actual Occupancy	Error	Error <sup>2</sup>	RMSE
LEONWEST	4	23	9	7	2	4	<b>1.541104</b>
LEONWEST	5	0	12	8	4	16	
LEONWEST	5	1	12	11	1	1	
LEONWEST	5	2	13	11	2	4	
LEONWEST	5	3	13	13	0	0	
LEONWEST	5	4	13	13	0	0	
LEONWEST	5	5	13	11	2	4	
LEONWEST	5	6	13	9	4	16	
LEONWEST	5	7	13	8	5	25	<b>2.872281</b>
LEONWEST	5	8	6	7	-1	1	
LEONWEST	5	9	6	4	2	4	
LEONWEST	5	10	6	5	1	1	
LEONWEST	5	11	6	6	0	0	
LEONWEST	5	12	6	7	-1	1	
LEONWEST	5	13	6	2	4	16	
LEONWEST	5	14	6	5	1	1	
LEONWEST	5	15	6	4	2	4	<b>1.870829</b>
LEONWEST	5	16	6	4	2	4	
LEONWEST	5	17	6	6	0	0	
LEONWEST	5	18	6	4	2	4	
LEONWEST	5	19	6	4	2	4	
LEONWEST	5	20	6	4	2	4	
LEONWEST	5	21	7	5	2	4	
LEONWEST	5	22	8	9	-1	1	
LEONWEST	5	23	9	11	-2	4	<b>1.767767</b>

## Regression Models

X axis: hours

Y axis: actual occupancy

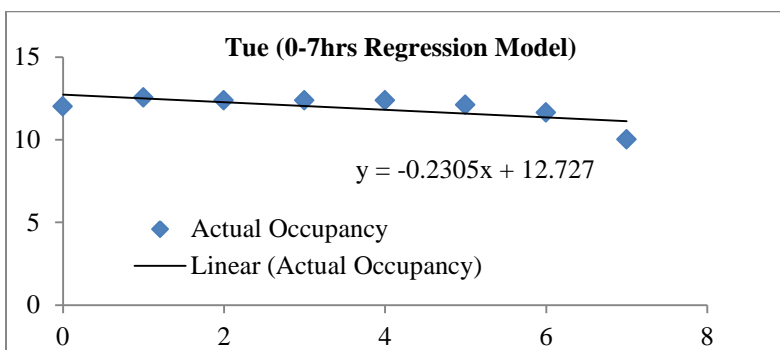
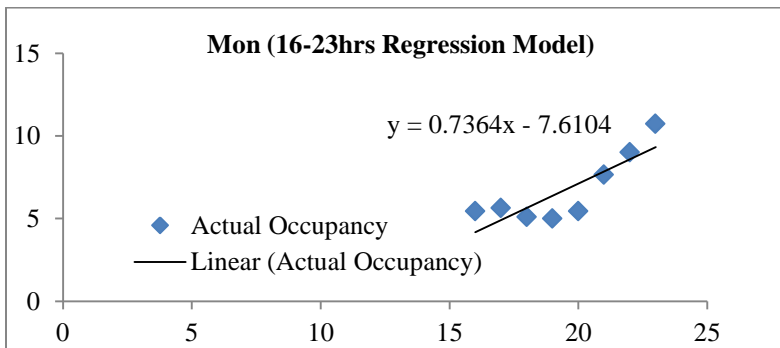
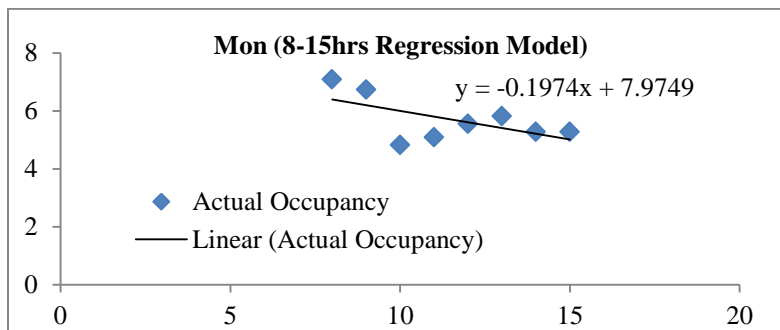
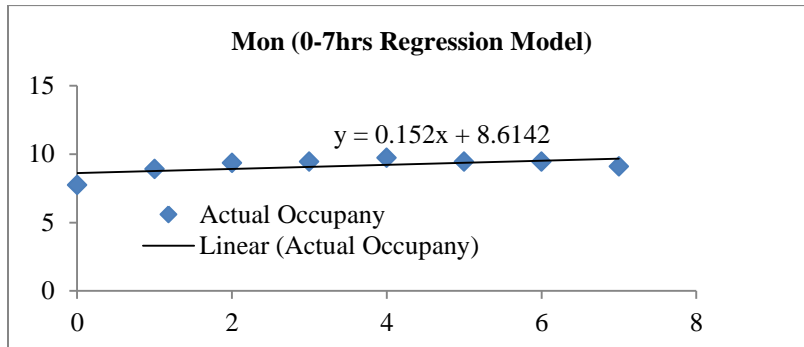

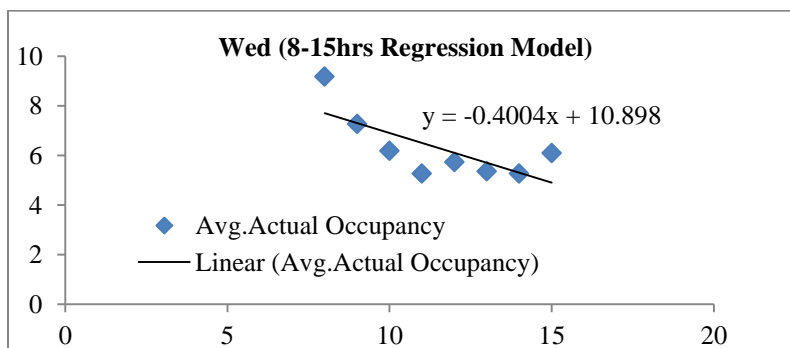
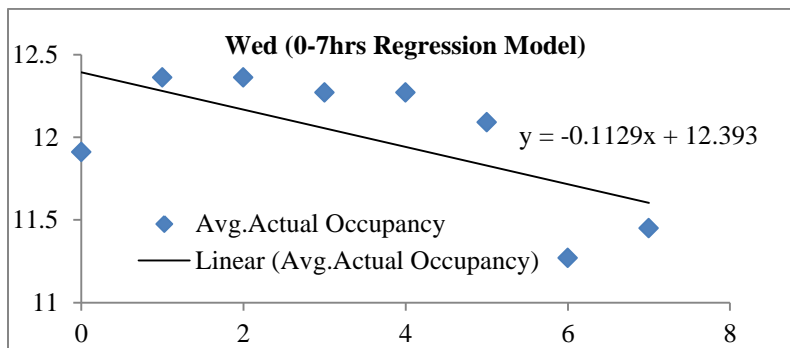
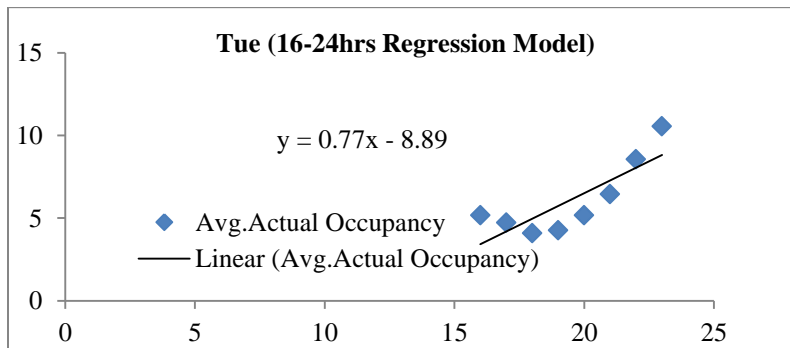
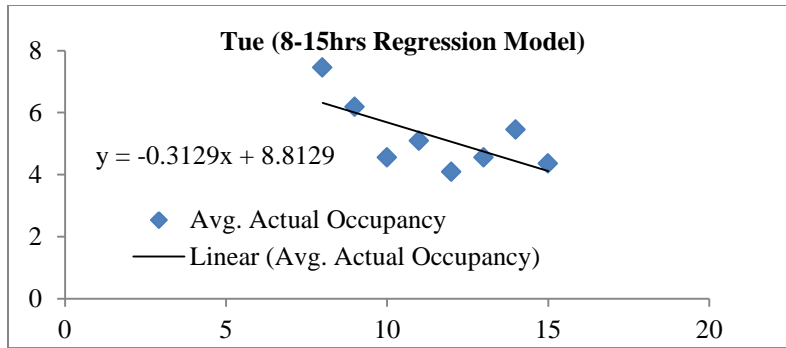



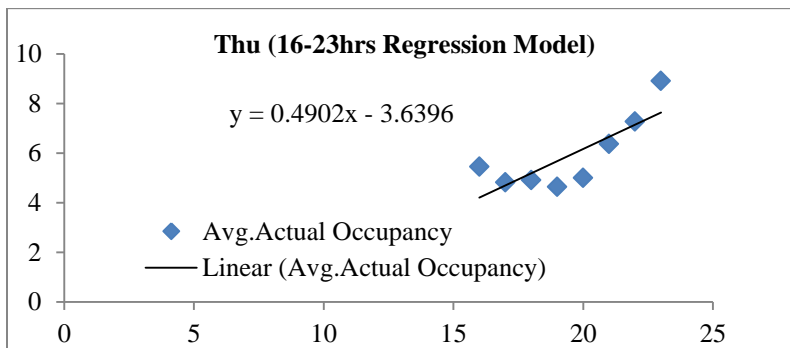
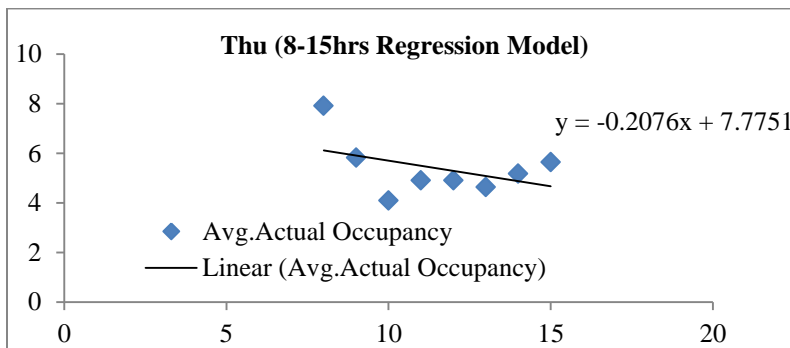
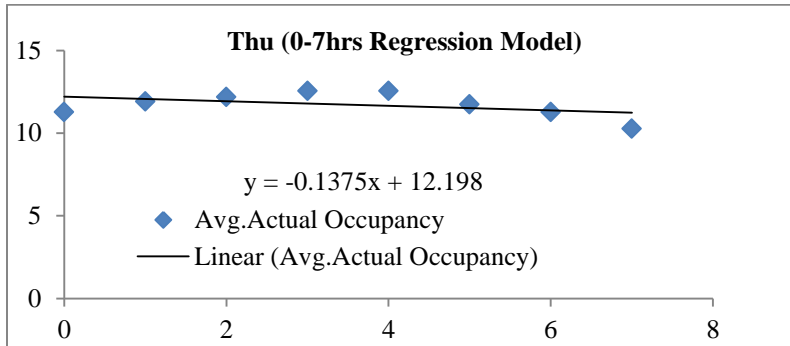
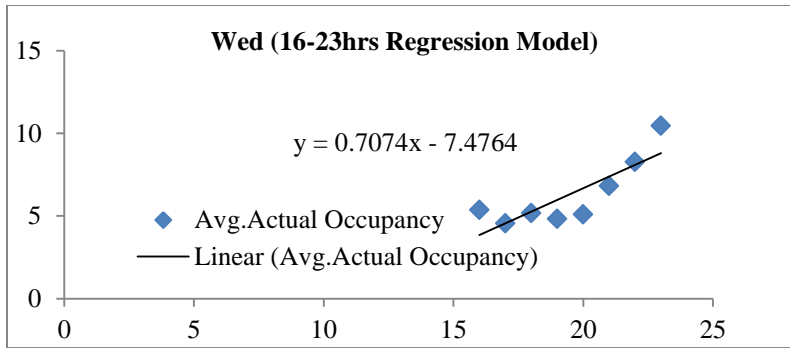

**Root Mean Squared Error Calculations (Regression Model)**

<b>Rest Area</b>	<b>Day of Week</b>	<b>Hour of Day</b>	<b>Average</b>	<b>Predicted</b>	<b>Actual</b>	<b>Error</b>	<b>Error<sup>2</sup></b>	<b>RMSE</b>
LEONWEST	2	0	7.73	9	12	-3	11	
LEONWEST	2	1	8.91	9	13	-4	18	
LEONWEST	2	2	9.36	9	13	-4	17	
LEONWEST	2	3	9.45	9	13	-4	15	
LEONWEST	2	4	9.73	9	12	-3	8	
LEONWEST	2	5	9.45	9	11	-2	3	
LEONWEST	2	6	9.45	10	12	-2	6	
LEONWEST	2	7	9.09	10	11	-1	2	<b>3.156726</b>
LEONWEST	2	8	7.09	6	9	-3	7	
LEONWEST	2	9	6.73	6	5	1	1	
LEONWEST	2	10	4.82	6	3	3	9	
LEONWEST	2	11	5.09	6	4	2	3	
LEONWEST	2	12	5.55	6	5	1	0	
LEONWEST	2	13	5.82	5	3	2	6	
LEONWEST	2	14	5.27	5	3	2	5	
LEONWEST	2	15	5.27	5	5	0	0	<b>1.985433</b>
LEONWEST	2	16	5.45	4	7	-3	8	
LEONWEST	2	17	5.64	5	7	-2	4	
LEONWEST	2	18	5.09	6	5	1	0	
LEONWEST	2	19	5	6	4	2	6	
LEONWEST	2	20	5.45	7	7	0	0	
LEONWEST	2	21	7.64	8	8	0	0	
LEONWEST	2	22	9	9	8	1	0	
LEONWEST	2	23	10.73	9	10	-1	0	<b>1.553028</b>
LEONWEST	3	0	12	10	10	0	0	
LEONWEST	3	1	12.55	10	13	-3	10	
LEONWEST	3	2	12.36	10	12	-2	5	
LEONWEST	3	3	12.36	10	12	-2	5	
LEONWEST	3	4	12.36	10	13	-3	10	
LEONWEST	3	5	12.09	10	12	-2	4	
LEONWEST	3	6	11.64	10	10	0	0	
LEONWEST	3	7	10	10	10	0	0	<b>2.037111</b>
LEONWEST	3	8	7.45	6	5	1	2	
LEONWEST	3	9	6.18	7	4	3	8	
LEONWEST	3	10	4.55	7	2	5	29	
LEONWEST	3	11	5.09	7	3	4	18	

Space	Day of Week	Hour of Day	Average	Predicted	Actual	Error	Error <sup>2</sup>	RMSE
LEONWEST	3	12	4.09	8	2	6	31	
LEONWEST	3	13	4.55	7	6	1	2	
LEONWEST	3	14	5.45	7	6	1	1	
LEONWEST	3	15	4.36	7	4	3	12	<b>3.588259</b>
LEONWEST	3	16	5.18	-5	5	-10	98	
LEONWEST	3	17	4.73	-5	5	-10	105	
LEONWEST	3	18	4.09	-6	5	-11	115	
LEONWEST	3	19	4.27	-6	5	-11	112	
LEONWEST	3	20	5.18	-5	4	-9	79	
LEONWEST	3	21	6.45	-4	10	-14	194	
LEONWEST	3	22	8.55	-2	11	-13	177	
LEONWEST	3	23	10.55	-1	13	-14	190	<b>11.56775</b>
LEONWEST	4	0	11.91	11	13	-2	4	
LEONWEST	4	1	12.36	11	13	-2	4	
LEONWEST	4	2	12.36	11	13	-2	4	
LEONWEST	4	3	12.27	11	13	-2	4	
LEONWEST	4	4	12.27	11	13	-2	4	
LEONWEST	4	5	12.09	11	12	-1	1	
LEONWEST	4	6	11.27	11	12	-1	1	
LEONWEST	4	7	11.45	11	11	0	0	<b>1.639166</b>
LEONWEST	4	8	9.18	7	6	1	1	
LEONWEST	4	9	7.27	8	6	2	4	
LEONWEST	4	10	6.18	8	6	2	6	
LEONWEST	4	11	5.27	9	6	3	8	
LEONWEST	4	12	5.73	9	7	2	3	
LEONWEST	4	13	5.36	9	7	2	3	
LEONWEST	4	14	5.27	9	8	1	1	
LEONWEST	4	15	6.09	8	11	-3	6	<b>1.993863</b>
LEONWEST	4	16	5.36	-4	8	-12	137	
LEONWEST	4	17	4.55	-4	7	-11	127	
LEONWEST	4	18	5.18	-4	6	-10	96	
LEONWEST	4	19	4.82	-4	5	-9	82	
LEONWEST	4	20	5.09	-4	7	-11	118	
LEONWEST	4	21	6.82	-3	7	-10	93	
LEONWEST	4	22	8.27	-2	5	-7	44	
LEONWEST	4	23	10.45	0	7	-7	50	<b>9.66491</b>
LEONWEST	5	0	11.27	11	8	3	7	
LEONWEST	5	1	11.91	11	11	0	0	
LEONWEST	5	2	12.18	11	11	0	0	
LEONWEST	5	3	12.55	10	13	-3	6	

Space	Day of Week	Hour of Day	Average	Predicted	Actual	Error	Error <sup>2</sup>	RMSE
LEONWEST	5	4	12.55	10	13	-3	6	
LEONWEST	5	5	11.73	11	11	0	0	
LEONWEST	5	6	11.27	11	9	2	3	
LEONWEST	5	7	10.27	11	8	3	8	<b>1.964134</b>
LEONWEST	5	8	7.91	6	7	-1	1	
LEONWEST	5	9	5.82	7	4	3	7	
LEONWEST	5	10	4.09	7	5	2	4	
LEONWEST	5	11	4.91	7	6	1	1	
LEONWEST	5	12	4.91	7	7	0	0	
LEONWEST	5	13	4.64	7	2	5	23	
LEONWEST	5	14	5.18	7	5	2	3	
LEONWEST	5	15	5.64	7	4	3	7	<b>2.358649</b>
LEONWEST	5	16	5.45	-1	4	-5	25	
LEONWEST	5	17	4.82	-1	6	-7	53	
LEONWEST	5	18	4.91	-1	4	-5	27	
LEONWEST	5	19	4.64	-1	4	-5	29	
LEONWEST	5	20	5	-1	4	-5	27	
LEONWEST	5	21	6.36	-1	5	-6	30	
LEONWEST	5	22	7.27	0	9	-9	82	
LEONWEST	5	23	8.91	1	11	-10	106	<b>6.883816</b>